



Government of **Western Australia**
School Curriculum and Standards Authority



ENGINEERING STUDIES
ATAR COURSE

DATA BOOK

2026

This page has been left blank intentionally

CONTENT	PAGES
<hr/>	
Core	
Base International System (SI) units	4
Derived SI units	4
SI prefixes	4
Common constant	4
Right triangular plane figures	5
Circles, cylinder and sphere figures	5
Density	5
Energy, work and power	5
Mechanisms	6
Efficiency	6
Selected materials properties (at 25 °C)	7
<hr/>	
Specialist field: Mechanical	
Base International System (SI) units	8
Derived SI units	8
Common constant	8
Materials formulae	9
Statics formulae	9
Dynamics formulae	9
Second moment of area for materials cross sections (I_{xx})	10
Deflection of beams	11
<hr/>	
Specialist field: Mechatronics	
Base International System (SI) units	12
Derived SI units	12
Laws and principles formulae	12
Diode and transistor models	14
Resistor colour codes	15
Sample microcontroller chip	15
Standard circuit symbols	16
Flow chart symbols	18
<hr/>	

Base International System (SI) units

Physical quantity		SI units	
Name	Symbol	Name	Symbol
Length	L	metre	m
Mass	m	kilogram	kg
Time	t	second	s

Derived SI units

Derived physical quantities		SI units	
Name	Symbol	Name	Symbol
Area	A	square metre	m^2
Volume	V	cubic metre	m^3
Density	ρ	kilogram per cubic metre	$kg\ m^{-3}$
Energy	E	joule	J
Work	W		
Displacement	s	metre	m
Distance	d		
Power	P	watt	W
Speed	no symbol	metre per second	$m\ s^{-1}$
Velocity (linear)	v		
Angular displacement	θ	radian	rad
Velocity (angular)	ω	radian per second	$rad\ s^{-1}$
Force	F	newton	N
Torque	τ	newton metre	N m

SI prefixes

Prefixes	Abbreviations	Multipliers
Tera	T	$10^{12} = 1\ 000\ 000\ 000\ 000$
Giga	G	$10^9 = 1\ 000\ 000\ 000$
Mega	M	$10^6 = 1\ 000\ 000$
Kilo	k	$10^3 = 1000$
		$10^0 = 1$
Milli	m	$10^{-3} = 0.001$
Micro	μ	$10^{-6} = 0.000\ 001$
Nano	n	$10^{-9} = 0.000\ 000\ 001$
Pico	p	$10^{-12} = 0.000\ 000\ 000\ 001$

Common constant

Item	Symbol	Value
Gravity	g	$9.80\ m\ s^{-2}$

Right triangular plane figures

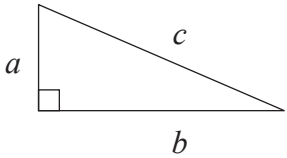
Parameter	Formulae
Pythagoras' theorem 	$a^2 + b^2 = c^2$
Angular relationships	$\cos \theta = \frac{a}{h}$ $\sin \theta = \frac{o}{h}$ $\tan \theta = \frac{o}{a}$

Circles, cylinder and sphere figures

Parameter	Formulae
Circumference (C) of a circle	$C = \pi d$
Area (A) of a circle	$A = \pi r^2$
Surface area (A) of open-ended cylinder	$A = \pi dh$
Surface area (A) of a sphere	$A = 4\pi r^2$
Volume (V) of a cylinder	$V = \pi r^2 h$
Volume (V) of a sphere	$V = \frac{4}{3} \pi r^3$

Density

Parameter	Formula
Density (ρ)	$\rho = \frac{m}{V}$

Energy, work and power

Parameter	Formulae
Energy (E)	$E = Pt$
Gravitational potential energy (E_p)	$E_p = mg\Delta h$
Kinetic energy (E_k)	$E_k = \frac{1}{2}mv^2$
Work done (W)	$W = \Delta E$
Work (W) linear	$W = Fs = F\Delta x = F(x_f - x_i)$
Work (W) rotational	$W = \tau\theta$
Power (P)	$P = \frac{\Delta E}{\Delta t} = \frac{W}{\Delta t}$
Power (P) linear	$P = \frac{Fs}{\Delta t} = \frac{F\Delta x}{\Delta t} = \frac{F(x_f - x_i)}{\Delta t} = Fv$
Power (P) rotational	$P = \frac{\tau\theta}{t} = \tau\omega = \tau \frac{(\text{rpm})(2\pi)}{60}$

Mechanisms

Parameter	Formulae
Mechanical advantage (<i>MA</i>)	$MA = \frac{F_{load}}{F_{effort}}$
Velocity ratio (<i>VR</i>)	$VR = \frac{d_{effort}}{d_{load}}$
Ideal machine (100% efficient)	$MA = VR$
Pulley belt ratio (<i>VR</i>)	$VR = \frac{\varnothing_{follower}}{\varnothing_{driver}}$
Chain and sprocket ratio (<i>VR</i>)	$VR = \frac{n^{\circ} \text{teeth}_{(follower)}}{n^{\circ} \text{teeth}_{(driver)}}$
Gear ratio (<i>VR</i>)	
Compound gear or pulley ratio (<i>VR</i>) comprised of 3 or more gears or pulleys	$VR = \frac{F_1 F_2 F_3 \dots}{D_1 D_2 D_3}$
Worm and worm wheel (<i>VR</i>)	$VR = \frac{n^{\circ} \text{teeth}_{(worm wheel)}}{1}$
Rack and pinion (<i>VR</i>)	$distance\ moved = \frac{n^{\circ} \text{teeth pinion} \times n^{\circ} \text{revolutions}}{n^{\circ} \text{teeth per metre rack}}$
Lead screw (<i>VR</i>)	<p>single start $distance\ moved = pitch \times revolutions$</p> <p>multiple start $distance\ moved = n^{\circ} \text{starts} \times pitch \times revolutions$</p>
Speed (linear translation)	$speed = \frac{\Delta x}{\Delta t} = \frac{x_f - x_i}{t_f - t_i}$
Speed (rotational to linear translation)	$speed = \frac{(rpm)(2\pi r)}{60}$
Speed of rotation (<i>rpm</i>)	$output\ speed\ (rpm) = \frac{input\ speed\ (rpm)}{VR}$
Torque (force perpendicular to lever arm)	$\tau = rF$

Efficiency

Parameter	Formula
Efficiency (η) %	$\eta = \frac{output}{input} \times 100\%$

Selected materials properties (at 25 °C)

Material	Density kg m ⁻³	Elastic (Young's) modulus kN mm ⁻²	Ultimate tensile strength N mm ⁻²	Yield stress N mm ⁻²	Ultimate shear stress N mm ⁻²	Electrical conductivity Ω ⁻¹ m ⁻¹ × 10 ⁶	Thermal conductivity W m ⁻¹ K ⁻¹	
Aluminium	2710	70	150	95	Assume ultimate shear stress (USS) is 70% of ultimate tensile strength (UTS)	37.70	237	
Copper	8930	112	210	70		59.50	401	
Zinc	7130	108	200	13.80		16.80	116	
Wrought iron	7750	200				10.30	80	
Structural steel	7850	200	470	250		13.00	46	
Stainless steel	7600	200	860	502		1.35	16	
Cast iron	7200	120	180			10.30	80	
Brass	8740	90	190	50		16.70	109	
Bronze	8800	105	467	282		7.25	60	
Acrylic	1190	3.20	70.00	73.70				0.19
Polycarbonate	1200	2.39	64.20	62.50				0.22
ABS	1070	2.35	40.90	44.80				0.16
PLA	1250	2.37	58.80	30.00			0.04	
PVC	1380	2.16	16.60	43.20			0.16	
Polypropylene	930	1.67	29.20	31.70			0.16	
Epoxy resin	1100	2.17	56				0.35	
Polyester resin	1100	25.00	250				0.40	
Concrete	2400	30	40 (compressive)				0.80	
Pine (along grain)	550	9	40					
Pure water	1000							
Sea water	1022							

Note: The values shown in the above chart are indicative of typical values for these materials and are to be only used for the purposes of this course.

Base International System (SI) units

Physical quantity		SI units	
Name	Symbol	Name	Symbol
Length	L	metre	m
Mass	m	kilogram	kg
Time	t	second	s

Derived SI units

Derived physical quantities		SI units	
Name	Symbol	Name	Symbol
Stress	σ	pascal	Pa
Pressure	P		
Force	F	newton	N
Area	A	square metre	m ²
Strain	ε	dimensionless number	
Young's modulus	E	kilonewton per square millimetre	kN mm ⁻²
		gigapascal	GPa
Moment	M	newton metre	N m
Acceleration	a	metre per second squared	m s ⁻²
Velocity	v	metre per second	m s ⁻¹
Displacement	s	metre	m
Distance	d		
Maximum deflection	y	millimetre	mm
Second moment of area	I_{xx}	millimetre to the power of four	mm ⁴

Common constant

Item	Symbol	Value
Gravity	g	9.80 m s ⁻²

Materials formulae

Parameter	Formulae
Stress (σ)	$\sigma = \frac{F}{A}$
Pressure (P)	$P = \frac{F}{A}$
Strain (ε)	$\varepsilon = \frac{\Delta L}{L}$
Young's Modulus (E)	$E = \frac{\sigma}{\varepsilon}$ $E = \frac{FL}{A\Delta L}$
Factor of Safety (FS)	$FS = \frac{\sigma_{UTS}}{\sigma_{safeworking}}$

Statics formulae

Parameter	Formulae
Moment (M) of a force	$M = Fd$
Equilibrium conditions – moments (M)	$\Sigma M = 0$
Note: CWM are positive	$\Sigma CWM = \Sigma ACWM$
Equilibrium conditions – horizontal forces (F_x)	$\Sigma F_x = 0$
Note: F_{right} are positive	$\Sigma F_{left} = \Sigma F_{right}$
Equilibrium conditions – vertical forces (F_y)	$\Sigma F_y = 0$
Note: F_{up} are positive	$\Sigma F_{up} = \Sigma F_{down}$
Where position of maximum bending moment (x) occurs along a UDL as measured from start of UDL	$x = \frac{y}{m}$

Dynamics formulae

Parameter	Formulae
Force (F)	$F = ma$
Acceleration (a)	$a = \frac{\Delta v}{\Delta t} = \frac{v_f - v_i}{t_f - t_i}$
Velocity (v)	$v_f = v_i + a\Delta t$
	$v_f^2 = v_i^2 + 2as$
Displacement (s)	$s = v_i\Delta t + \frac{1}{2}a\Delta t^2$

Second moment of area for materials cross sections (I_{xx})

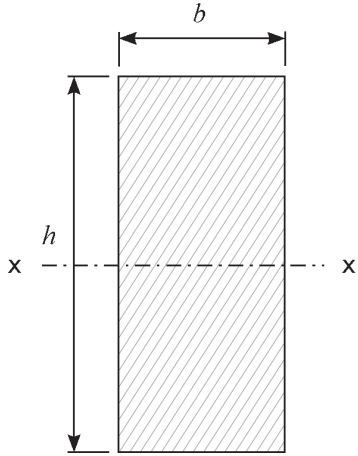
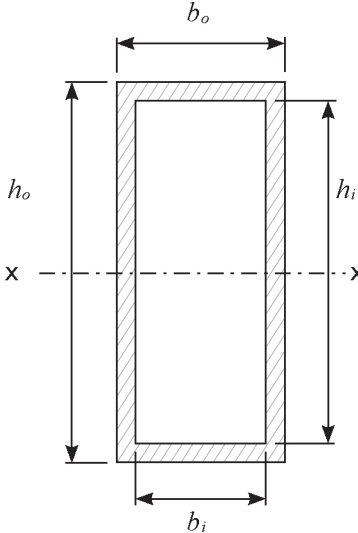
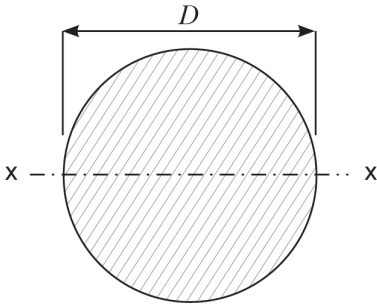
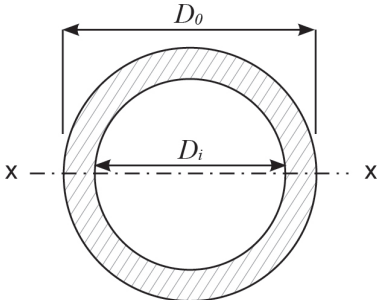
Shapes	Dimensions	Second moment of area about centroid axis
<p>Vertical rectangle solid section</p>		$I_{xx} = \frac{bh^3}{12}$ <p>b = base h = height</p>
<p>Vertical rectangle hollow section</p>		$I_{xx} = \frac{b_o h_o^3}{12} - \frac{b_i h_i^3}{12}$ <p>b_o = base (outside) h_o = height (outside) b_i = base (inside) h_i = height (inside)</p>
<p>Round solid section</p>		$I_{xx} = \frac{\pi D^4}{64}$ <p>D = diameter</p>
<p>Circular tube section</p>		$I_{xx} = \frac{\pi (D_o^4 - D_i^4)}{64}$ <p>D_o = diameter (outside) D_i = diameter (inside)</p>

Deflection of beams

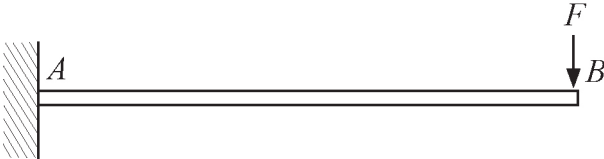
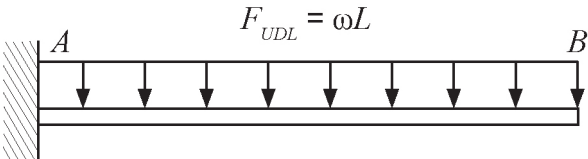
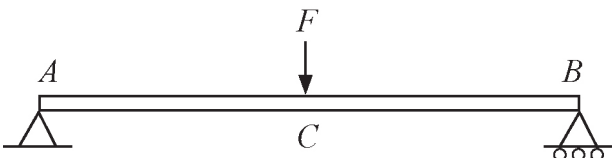
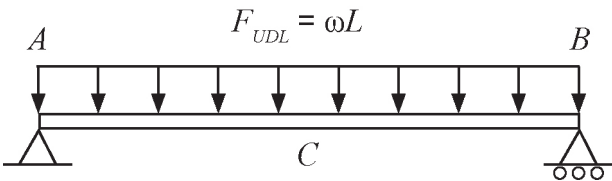
Beam configurations	Maximum deflection (y)
<p>Cantilevered beam – single load at unsupported end</p> 	$y = \frac{FL^3}{3EI_{xx}} \text{ at } B$
<p>Cantilevered beam – universally distributed load</p> 	$y = \frac{F_{UDL}L^3}{8EI_{xx}} \text{ at } B$
<p>Centrally loaded beam – simply supported at both ends</p> 	$y = \frac{FL^3}{48EI_{xx}} \text{ at } C$
<p>Universally loaded beam – simply supported at both ends</p> 	$y = \frac{5F_{UDL}L^3}{384EI_{xx}} \text{ at } C$
<p>Terms</p> <p>E = elastic (Young's) modulus of the material of the beam</p> <p>F = single vertical point load</p> <p>F_{UDL} = product of ω and the length of the beam</p> <p>I_{xx} = second moment of area of the beam section</p> <p>L = length of beam</p> <p>ω = uniformly distributed load per unit length</p>	

Base International System (SI) units

Physical quantity		SI units	
Name	Symbol	Name	Symbol
Current	I	ampere	A

Derived SI units

Derived physical quantities		SI units	
Name	Symbol	Name	Symbol
Charge	q	coulomb	C
Capacitance	C	farad	F
Voltage	V	volt	V
Resistance	R	ohm	Ω
Power	P	watt	W
Frequency	f	hertz	Hz

Laws and principles formulae

Parameter	Formulae
Charge (q)	$q = It$
Relationships between Ohm's law and power formula	
Voltage (V)	$V = IR = \frac{P}{I} = \sqrt{PR}$
Current (I)	$I = \frac{V}{R} = \frac{P}{V} = \sqrt{\frac{P}{R}}$
Resistance (R)	$R = \frac{V}{I} = \frac{P}{I^2} = \frac{V^2}{P}$
Power (P)	$P = VI = I^2R = \frac{V^2}{R}$
Kirchhoff's voltage law	$\Sigma \Delta V = 0$
Kirchhoff's current law	$\Sigma I = 0$
Resistances (R) in series	$R_T = R_1 + R_2 + \dots$
Resistances (R) in parallel	$\frac{1}{R_T} = \frac{1}{R_1} + \frac{1}{R_2} + \dots$
Charge (q) capacitor	$q = CV$
Charge (q) capacitances in series	$q_T = q_1 = q_2 = \dots$
Charge (q) capacitances in parallel	$q_T = q_1 + q_2 + \dots$
Capacitances (C) in series	$\frac{1}{C_T} = \frac{1}{C_1} + \frac{1}{C_2} + \dots$
Capacitances (C) in parallel	$C_T = C_1 + C_2 + \dots$

Laws and principles formulae (continued)

Parameter	Formulae
Current capacity ($A h$) cells and batteries	$Ah = \frac{Wh}{V}$
Cells and batteries in series	$V_T = V_1 + V_2 + \dots$ $I_T = I_1 = I_2 = \dots$
Cells and batteries in parallel	$I_T = I_1 + I_2 + \dots$ $V_T = V_1 = V_2 = \dots$
Voltage dividers	$V_{CC} = V_1 + V_2$ $V_1 = V_{CC} \times \frac{R_1}{R_1 + R_2}$ $V_2 = V_O = V_{CC} \times \frac{R_2}{R_1 + R_2}$
Resistor (R) in series with an LED	$R = \frac{V_{cc} - V_{LED}}{I_{LED}}$
Frequency (f)	$f = \frac{1}{t}$

Diode and transistor models

Diode model	Formulae	Diagram
On	$V_D = V_{D,ON}$ (or V_F) Check: $I_D > 0 \text{ A}$	
Off	$I_D = 0 \text{ A}$ Check: $V_D < V_{D,ON}$ (or V_F)	
Transistor model (NPN)	Formulae	Diagram
Cut-off	$I_B = I_C = 0 \text{ A}$ Check: $V_{BE} < 0.7 \text{ V}$	
Saturation	$V_{BE} = 0.7 \text{ V}$ $V_{CE} = 0 \text{ V}$ Check: $I_B > 0 \text{ A}$ $\frac{I_C}{I_B} < \beta$ (or h_{FE})	
Forward-active	$V_{BE} = 0.7 \text{ V}$ $\beta = \frac{I_C}{I_B}$ Check: $I_B > 0 \text{ A}$ $V_{CE} > 0 \text{ V}$	
Darlington pair	Formulae	
Gain (β or h_{FE})	$\beta_{total} = \beta_1 \times \beta_2$	
Base-emitter voltage	$V_{BE, total} = V_{BE1} + V_{BE2}$ $= 0.7 + 0.7$ $= 1.4 \text{ V}$	

Resistor colour codes

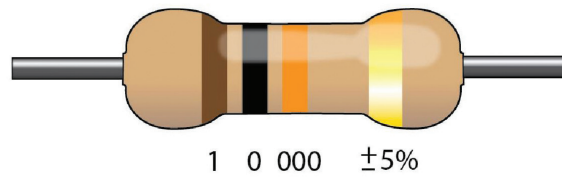

Example: 4-band E12 resistor colour code

Band colours	Band 1	Band 2	Band 3 (multiplier)	Band 4 (tolerance)
Black	0	0	1	
Brown	1	1	10	± 1%
Red	2	2	100	± 2%
Orange	3	3	1000	
Yellow	4	4	10 000	
Green	5	5	100 000	
Blue	6	6	1 000 000	
Violet	7	7		
Grey	8	8		
White	9	9		
Gold			0.1	± 5%

E12 Preferred values: 10, 12, 15, 18, 22, 27, 33, 39, 47, 56, 68 and 82

Sample microcontroller

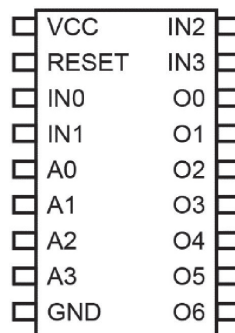

Standard circuit symbols

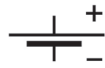

Cell



Battery

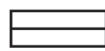

Fuse



SPST switch

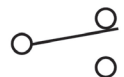

SPDT switch

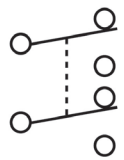

DPDT switch

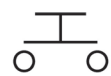

Push-to-make
switch



Push-to-break
switch



Magnetic
reed switch



Terminals for power
supply unit (PSU)



Voltage regulator



Polarised and
non-polarised capacitor



Resistor



Thermistor



Potentiometer

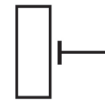

Variable resistor

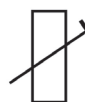

SPST relay

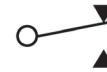

DPDT relay

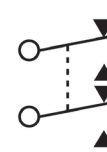

Standard circuit symbols (continued)



Voltmeter



Ammeter



Ohmmeter



NPN transistor



Diode



Motor

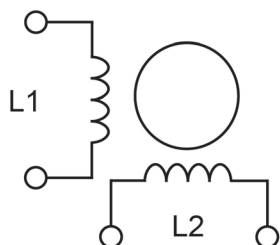

Bipolar stepper motor

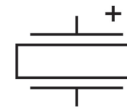

Piezo sounder



Electromagnet
(solenoid)



Darlington pair

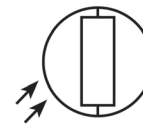

Light dependent
resistor



Light emitting
diode

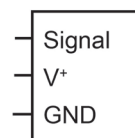

Servo

Flow chart symbols

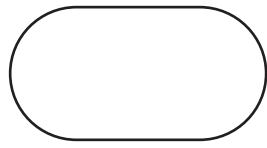

Terminator – start or end of a program or subroutine



Output to a device



Delay or computational process

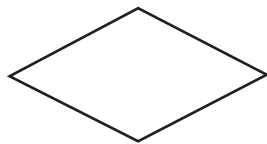

Decision with Yes/No result

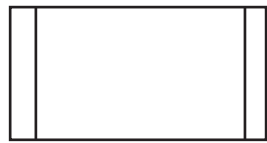

Subroutine – a predefined process



Flow of computation

This page has been left blank intentionally

Copyright

© School Curriculum and Standards Authority, 2025

This document – apart from any third-party copyright material contained in it – may be freely copied, or communicated on an intranet, for non-commercial purposes in educational institutions, provided that it is not changed and that the School Curriculum and Standards Authority (the Authority) is acknowledged as the copyright owner, and that the Authority's moral rights are not infringed.

Copying or communication for any other purpose can be done only within the terms of the *Copyright Act 1968* or with prior written permission of the Authority. Copying or communication of any third-party copyright material can be done only within the terms of the *Copyright Act 1968* or with permission of the copyright owners.

Any content in this document that has been derived from the Australian Curriculum may be used under the terms of the Creative Commons [Attribution 4.0 International \(CC BY\)](https://creativecommons.org/licenses/by/4.0/) licence.

This document is valid for teaching and examining until 31 December 2026.

*Published by the School Curriculum and Standards Authority of Western Australia
303 Sevenoaks Street
CANNINGTON WA 6107*