



# **ENGINEERING STUDIES**

## **ATAR course sample examination**

### **Marking key**

Marking keys are an explicit statement about what the examining panel expect of candidates when they respond to particular examination items. They help ensure a consistent interpretation of the criteria that guide the awarding of marks.

## Section One: Core content

50% (90 Marks)

## Part A:

10% (19 Marks)

## Question 1

(2 marks)

You have been asked to design a child's toy. One of the requirements of the brief is that the toy must be able to move independently, without any external force being applied. Name **two** suitable energy sources that could be used.

Description	Marks
Any two of	
<ul style="list-style-type: none"> <li>• battery</li> <li>• spring</li> <li>• gravity/potential energy, e.g. hot wheels track</li> <li>• kinetic/flywheel</li> </ul>	1-2
<b>Total</b>	<b>2</b>

## Question 2

(2 marks)

State why steel, stainless steel and cast iron can be classified as a ferrous alloy.

Description	Marks
ferrous – contains iron	1
alloy – mixture of metals	1
<b>Total</b>	<b>2</b>

## Question 3

(3 marks)

Automotive windshields are made by layering sheets of glass and plastic. Identify and describe the type of material used for a windshield.

Description	Marks
composite material	1
combination of two or more materials	1
exhibits properties that are distinctly different to those of the individual materials	1
<b>Total</b>	<b>3</b>

## Question 4

(2 marks)

A 6 m long square hollow section structural steel tube has external dimensions of 100 mm x 100 mm. Calculate the mass of the steel tube if thickness of its walls is 5mm.

Description	Marks
$(0.1^2 - 0.09^2) \times 6 = 0.0114 \text{ m}^2$	1
$0.0114 \times 7850 = 89.49 \text{ kg}$	1
<b>Total</b>	<b>2</b>

## Question 5

(3 marks)

In an Engineering design process, state **three** types of activities that could be considered as 'investigating'.

Description	Marks
Any three of	
<ul style="list-style-type: none"> <li>• develop a comprehensive design brief</li> <li>• conduct research to identify and assess existing solutions or similar products</li> <li>• research and critique materials and components that are relevant to the design brief</li> <li>• consider different ways to supply energy for those parts of the design that require motion</li> </ul>	1–3
<b>Total</b>	<b>3</b>

## Question 6

(3 marks)

In a simple gear train, a 10-tooth pinion gear drives a 25-tooth idler gear, which in turn drives a 35-tooth output (follower) gear. State the velocity ratio ( $VR$ ) formula between the input and output gear and calculate the final  $VR$ .

Description	Marks
$VR = \frac{\text{O}_{follower}}{\text{O}_{driver}}$	
$VR = \frac{25}{10} \times \frac{35}{25} = 3.5$	1–3
<b>Total</b>	<b>3</b>

## Question 7

(2 marks)

A force of 500 N is required to slide a pallet of goods across the floor of a warehouse. Calculate how much power is required to slide the pallet a distance of 4 m in 3 seconds.

Description	Marks
Enters the correct values into the equation	1
Calculates the correct answer	1
<b>Total</b>	<b>2</b>
$P = \frac{F \times d}{t}$ $P = \frac{500 \times 4}{3} = 666.67 \text{ W}$	

## Question 8

(2 marks)

State **two** reasons why a manufacturer of an engineered product may conduct a life cycle analysis of one or a group of their products.

Description	Marks
Any two of	
<ul style="list-style-type: none"><li>• reduce waste</li><li>• improve efficiency</li><li>• reduce environmental impact</li><li>• increase profit</li><li>• obtain greener credentials/improve corporate image</li></ul>	1–2
<b>Total</b>	<b>2</b>

Part B:

40% (71 Marks)

Question 9

(20 marks)

- (a) When viewed from the direction indicated below, create the isometric view on the isometric grid provided on page 9. Dimensions are not required on the drawing, but an accurate scale must be used. (7 marks)

Description	Marks
Draws bottom base lines	1
Draws top base lines	1
Draws base holes in the correct location	1
Overall height of protrusions is correct	1
Places protrusions in the correct location	1
Chamfers	1
Places protrusion holes in correct location	1
<b>Total</b>	<b>7</b>

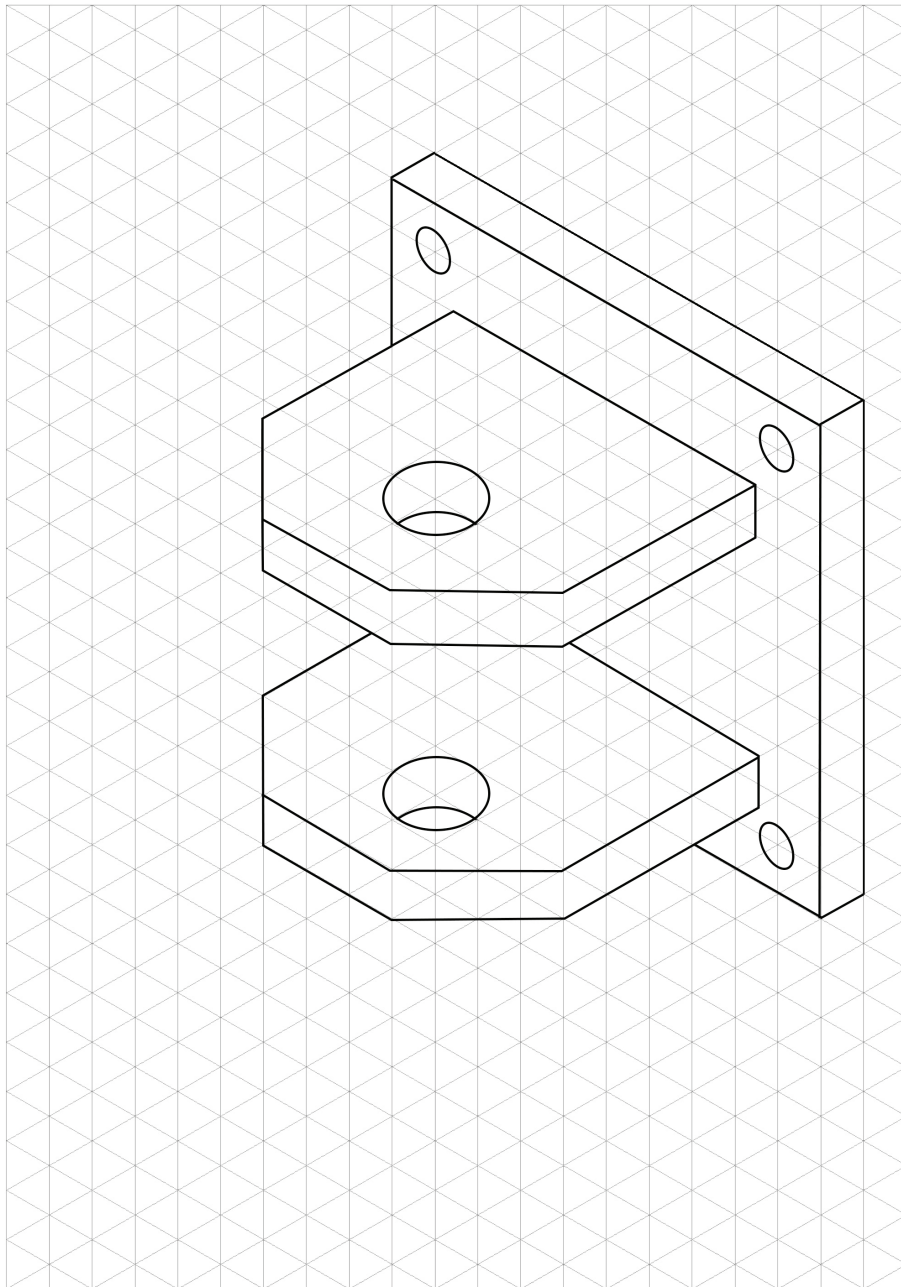

## Question 9 (continued)

- (b) State the
- four**
- main components of stainless steel. (4 marks)

Description	Marks
iron	1
carbon	1
chromium	1
nickel	1
<b>Total</b>	<b>4</b>

- (c) Calculate the mass of
- one**
- bracket. Ignore the small amount of material that is removed by the radius on the corners of the back plate. (9 marks)

Description	Marks
Calculates the volume of the base plate	1
Calculates the volume of one base hole	1
Accounts for the volume of four holes	1
Calculates the volume of rectangular portion of front plates	1
Calculates the volume of trapezoidal section of front plates	1
Calculates the volume of hole in front plate	1
Calculates the overall volume	1
Identifies the correct material density	1
Calculates mass	1
<b>Total</b>	<b>9</b>
Answers could include:	
Back plate:	$[0.1 \times 0.1 - 4(\pi \times 0.005^2)] \times 0.01 \times 7850 = 0.760 \text{ kg}$
Front plates:	$2[0.07 \times 0.07 - (\pi \times 0.01^2)] \times 0.01 \times 7850 = 0.720 \text{ kg}$
Total for one:	$0.760 + 0.720 = 1.48 \text{ kg}$
Total for 20:	$1.48 \times 20 = 29.6 \text{ kg}$
Note: Accept other valid methods of calculation and allow for rounding.	

Question 10

(12 marks)

- (a) Using the definitions of malleability and ductility, explain which of these properties is required in the manufacture of copper wire. (3 marks)

Description	Marks
malleable – ability to be hammered into thin sheets	1
ductile – ability to be drawn into wires	1
in this application, ductility of copper is required or malleability is not required in this application	1
<b>Total</b>	<b>3</b>

- (b) (i) Define the term ‘non-ferrous’. (1 mark)

Description	Marks
no iron in its composition	1
<b>Total</b>	<b>1</b>

- (ii) State what is an alloy. (1 mark)

Description	Marks
alloy is a mixture of metals	1
<b>Total</b>	<b>1</b>

- (iii) State the main components of brass. (1 mark)

Description	Marks
copper and zinc	1
<b>Total</b>	<b>1</b>

- (c) State **three** main properties that would influence the choice of material for a propeller on a large boat and outline clearly how these properties are relevant in this application. (6 marks)

Description	Marks
For each property (3 x 2 marks)	
States the property that would influence the choice of material	1
Outlines how the property is relevant to this application	1
<b>Subtotal</b>	<b>2</b>
<b>Total</b>	<b>6</b>

Answers could include:

- strength – ability of the propeller to withstand stresses the motor (or water) applies on it
- stiffness – ability of the propeller to resist deformation from the forces the motor (or water) applies on it
- toughness – ability of the propeller to absorb energy when being deformed and resist deformation and failure when it hits any object or obstacle in the water
- hardness – ability of the propeller to resist degradation of its surface due to the particles in the water by abrasion, scratching, indentation or penetration
- corrosion resistance – ability of the propeller to resist destruction by chemical or electrochemical means due to the sea water/stale water/chemicals in the water.

## Question 11

(10 marks)

- (a) When used, the maintenance, repair and refurbish activities may be repeated many times before the house comes to the end of its useful life and is demolished. Explain the importance of these activities in relation to the overall emission of CO<sub>2</sub> in the life of the building. (3 marks)

Description	Marks
Explains the importance of the activities in relation to the overall emission	3
Describes the importance of the activities in relation to the overall emission	2
States a reason for the importance of the activities in relation to the overall emission	1
<b>Total</b>	<b>3</b>
Answers could include:	
A lot of CO <sub>2</sub> is produced in the initial construction phase of a building. Repairing and maintaining extends the life of the building, and a longer useable life of building means that less CO <sub>2</sub> is produced building new or replacement buildings.	
Accept other relevant answers.	

- (b) Transport is identified at key points in the LCA diagram (construction, end of service, production) but transport affects every stage of the LCA. Outline **four** ways transport impacts CO<sub>2</sub> production while the building is in use. (4 marks)

Description	Marks
transport of all goods into the house while in use, e.g. furniture, shopping	1
transport of materials to site for maintenance	1
transport required by trades to get to site for repairs and maintenance	1
transport of occupants daily or when selling/relocating	1
<b>Total</b>	<b>4</b>
Accept other relevant answers.	

- (c) State **three** activities or materials from the building that could be involved in 'waste management' and would lead back to 'raw material supply'. (3 marks)

Description	Marks
Any three of	
<ul style="list-style-type: none"> <li>• bricks may be cleaned and re-used in new buildings or paving</li> <li>• building rubble can be crushed and lead back into levelling fill or driveways</li> <li>• furniture/structural timbers can be recycled as either second-hand or remanufactured furniture, or as timber waste that can be reused in manufactured boards</li> <li>• glass (windows) can be easily recycled into other glass products</li> <li>• ferrous and non-ferrous metals (steel beams, copper wire and pipes, aluminium window and door frames) can be recycled back into new products</li> </ul>	1–3
<b>Total</b>	<b>3</b>
Accept other relevant answers.	



Question 12

(15 marks)

- (a) Calculate the vertical change in height ( $h$ ) from the bottom, where the ride begins, to the top of the first hill. (4 marks)

Description	Marks
Motor input = $35\,000\text{ J s}^{-1} \times 15\text{ s}$ = 525 kJ	1
$525\text{ kJ} \times 0.4 = 210\text{ kJ}$	1
$E_p = mg\Delta h$ $\Delta h = \frac{E_p}{mg}$	1
$\Delta h = \frac{210\,000}{1100 \times 9.8}$ = 19.48 m	1
<b>Total</b>	<b>4</b>
Accept other valid methods of calculation.	

- (b) Assuming no energy is lost to friction or wind, calculate the speed of the roller coaster at the top of the third hill if it is 10 m high. If you could not calculate an answer for part (a), use 20 metres. (5 marks)

Description	Marks
$E_p = mg\Delta h$ = $1100 \times 9.8 \times 10$ = 107.8 kJ	1
$\Delta E_p = 210 - 107.8$ = 102.2 kJ	1
$E_k = \frac{1}{2}mv^2$ $v = \sqrt{\frac{2E_k}{m}}$	1
$v = \sqrt{\frac{2 \times 102\,200}{1100}}$ = 13.63 m s <sup>-1</sup>	1
<b>Total</b>	<b>5</b>
Accept other valid methods of calculation.	
Note: if used 20 m, $v = 14.0\text{ m s}^{-1}$ .	

**Question 12** (continued)

- (c) If the ride cycles around the track five times per hour for 12 hours per day, determine how many solar panels will be needed to make the ride sustainable without additional power being required. (6 marks)

Description	Marks
one solar panel produces $120 \text{ W} \times 8 \text{ hrs} \times 3600 \text{ s} = 3456 \text{ kJ}$	1
each ride requires 525 kJ (motor requirement)	1
$525 \times 5 \times 12 = 31\,500 \text{ kJ per day}$	1–2
$\frac{31\,500}{3456} = 9.11 \text{ panels}$	1
system will require at least 10 panels	1
<b>Total</b>	<b>6</b>

Question 13

(14 marks)

- (a) The conveyor belt needs to be able to load 240 items onto the plane in 12 minutes. Calculate the speed of the conveyor belt (in  $\text{m s}^{-1}$ ) to achieve this objective. Ignore the small amount of time required for the first box to travel the length of the conveyor belt. (3 marks)

Description	Marks
240 items in $12 \times 60 = 720$ seconds = 1 box every 3 seconds	1
distance between each box: $\frac{5 \text{ m}}{3 \text{ spaces}} = 1.67 \text{ m}$	1
belt speed: $\frac{d}{t} = \frac{1.67}{3} = 0.55 \text{ m s}^{-1}$	1
<b>Total</b>	<b>3</b>

- (b) Determine the angular velocity (in rpm) of the end rollers of the conveyor when the belt is travelling at this speed. If you could not calculate an answer to part (a), use  $0.5 \text{ m s}^{-1}$ . (2 marks)

Description	Marks
Uses correct values for the equation	1
Calculates the correct answer	1
<b>Total</b>	<b>2</b>
$v = \frac{\text{rpm} \times 2\pi r}{60}$ $\text{rpm} = \frac{60v}{2\pi r}$ $= \frac{60 \times 0.55}{2\pi \times 0.2}$ $= 26.26 \text{ rpm}$	
Note: If $0.5 \text{ m s}^{-1}$ used, $v = 23.87 \text{ rpm}$ .	

- (c) The force ( $F_L$ ) that the boxes exert parallel to the belt due to gravity can be calculated using  $F_L = mg \sin \theta$ . If the average mass of each item is 20 kg, prove by calculation that the force parallel to the belt when it is fully loaded with 4 boxes is close to 330 N. (1 mark)

Description	Marks
$F_L = 20 \times 4 \times 9.8 \times \sin 25 = 331.33 \text{ N}$	1
<b>Total</b>	<b>1</b>

- (d) Calculate the torque on the driven (follower) roller when the conveyor belt is fully loaded, given that it has a diameter of 400 mm. (1 mark)

Description	Marks
$\tau = rF = 0.2 \times 331.33$ $= 66.27 \text{ N m}$	1
<b>Total</b>	<b>1</b>

## Question 13 (continued)

- (e) The conveyor belt is driven by a 24 V DC motor that draws 20 A. Determine the efficiency of the conveyor belt's mechanical system. (3 marks)

Description	Marks
Motor power = $VA = 24 \times 20 = 480 \text{ W}$	1
$P = \tau \frac{(rpm)(2\pi)}{60}$ $= \tau \frac{(66.27)(19.91)(2\pi)}{60}$ $= 138.2 \text{ W}$	
Efficiency ( $\eta$ ) = $\frac{\text{output}}{\text{input}} \times 100 = \frac{138.2}{480} \times 100$ = 28.8%	1
<b>Total</b>	<b>3</b>
Note: If $P = 165.65 \text{ W}$ , efficiency = 34.5%	

- (f) The motor rotates at 2400 rpm and drives a 30-tooth single start worm drive gearbox. The output shaft of the gearbox has a pulley which moves the conveyor belt at  $0.55 \text{ m s}^{-1}$ . Calculate the diameter of this pulley. (4 marks)

Description	Marks
$\text{output speed (rpm) of gearbox} = \frac{\text{input speed (rpm)}}{VR}$ $= \frac{2400}{30}$ $= 80 \text{ rpm}$	1
$V = \frac{rpm (2 \times \pi \times r)}{60}$ $0.55 = \frac{80 \times (2 \times \pi \times r)}{60}$	1
$r = 0.0657 \text{ m}$	1
Diameter = $0.0657 \times 2$ = 0.1314 m	1
<b>Total</b>	<b>4</b>
Accept other valid methods of calculation.	

## Section Two: Mechanical

50% (98 Marks)

## Part A:

10% (12 Marks)

## Question 14

(2 marks)

Outline **one** advantage and **one** disadvantage of using a cast engine block.

Description	Marks
Outlines one advantage of using a cast engine block	1
Outlines one disadvantage of using a cast engine block	1
<b>Total</b>	<b>2</b>
Answers could include:  <b>Advantages</b> <ul style="list-style-type: none"> <li>• produces complex shapes</li> <li>• minimal wastage of materials</li> <li>• wear resistant surface (cast iron).</li> </ul> <b>Disadvantages</b> <ul style="list-style-type: none"> <li>• brittle</li> <li>• not as strong as billet materials</li> <li>• still require some machining.</li> </ul> Accept other relevant answers.	

## Question 15

(3 marks)

A structural steel lifting hook has a cross-sectional area of a 50 mm<sup>2</sup> and is rated to a safe working load of 11.75 kN. Determine the factor of safety of the hook.

Description	Marks
$\text{Stress } (\sigma) = \frac{F}{A} = \frac{11750}{50}$	1
$= 235 \text{ MPa}$	1
$FS = \frac{\sigma_{UTS}}{\sigma_{safeworking}} = \frac{470}{235} = 2$	1
<b>Total</b>	<b>3</b>

## Question 16

(3 marks)

A square solid beam has a  $I_{xx}$  of 520 833.4 mm<sup>4</sup>. Determine the cross-section height and width of the square beam.

Description	Marks
$I_{xx} = \frac{bh^3}{12}$ Square beam so $b = h$	1
$I_{xx} = \frac{h^4}{12}$ $h = \sqrt[4]{12 \times 520\,833.4}$	1
$= 50 \text{ mm}$	1
<b>Total</b>	<b>3</b>

## Question 17

(3 marks)

A 6 m long aluminium rod with a diameter of 5 mm is subjected to a force of 20 N. Determine the change in length of the rod with this force applied.

Description	Marks
$A = \pi r^2 = \pi \times 2.5^2 = 19.63 \text{ mm}^2$	1
$\Delta L = \frac{FL}{AE} = \frac{20 \times 6000}{19.63 \times 70\,000}$	1
= 0.087 mm	1
<b>Total</b>	<b>3</b>

## Question 18

(1 mark)

State the condition for rotational equilibrium.

Description	Marks
the sum of moments about any point is zero or sum of clockwise moments = sum of anti-clockwise moments	1
<b>Total</b>	<b>1</b>

## Part B:

40% (86 Marks)

## Question 19

(25 marks)

- (a) Using an equilibrium condition of your choice, prove by calculation that the reaction force at Point B is close to 31 kN. (4 marks)

Description	Marks
$\Sigma M_A = (6 \times 1.5) + (11 \times 4 \times 4) + (9 \times 7) - 8F_B = 0$	1
$= 9 + 176 + 63 - 8F_B = 0$	1
$8F_B = 248$	1
$F_B = 31 \text{ kN}$	1
<b>Total</b>	<b>4</b>

- (b) Using an equilibrium condition of your choice, prove by calculation that the reaction force at Point A is close to 28 kN. (2 marks)

Description	Marks
$\Sigma F_V = 31 - 6 - 44 - 9 + F_A = 0$	1
$F_A = 28 \text{ kN}$	1
<b>Total</b>	<b>2</b>

- (c) Calculate the shear forces at the sections along the length of the beam, indicated by letters C, D, E, F. (4 marks)

Description	Marks
$SF_C = 28 \text{ kN}$	1
$SF_D = 28 - 6 = 22 \text{ kN}$	1
$SF_E = 22 - 44 = -22 \text{ kN}$	1
$SF_F = -22 - 9 = -31 \text{ kN}$	1
<b>Total</b>	<b>4</b>

- (d) Calculate the bending moments at Points 1 to 6 along the length of the beam. (6 marks)

Description	Marks
$BM_1 = 0$	1
$BM_2 = 28 \times 1.5 = 42 \text{ kN m}$	1
$BM_3 = (28 \times 2) - (6 \times 0.5) = 53 \text{ kN m}$	1
$BM_4 = (28 \times 6) - (6 \times 4.5) - (11 \times 4 \times \frac{4}{2}) = 53 \text{ kN m}$	1
$BM_5 = (28 \times 7) - (6 \times 5.5) - (44 \times 3) = 31 \text{ kN m}$	1
$BM_6 = 0 \text{ kN m}$	1
<b>Total</b>	<b>6</b>

**Question 19** (continued)

- (e) Determine the position and value of the maximum bending moment. (3 marks)

Description	Marks
Position of $BM_{Max} = \frac{y}{m} = \frac{22}{11} = 2$ m from Point 3 or 4 m from A	1
Value of $BM_{Max} = (28 \times 4) - (6 \times 2.5) - (11 \times 2 \times \frac{2}{2})$	1
$= 112 - 15 - 22 = 75$ kN m	1
<b>Total</b>	<b>3</b>



- (f) On the diagram on page 31, construct shear force and bending moment diagrams for the beam, labelling a suitable scale and all key features. (6 marks)

Description	Marks
<b>Shear force diagram</b>	
Draws the correct shape	1
Uses the correct scale	1
Writes values in vertical hatching under graph	1
<b>Subtotal</b>	<b>3</b>
<b>Bending moment diagram</b>	
Draws correct shape: straight lines between point loads, curve under UDL	1
Uses the correct scale	1
Writes values in; hatching is not required	1
<b>Subtotal</b>	<b>3</b>
<b>Total</b>	<b>6</b>

Note: accept inverted shape depending on conventions used.

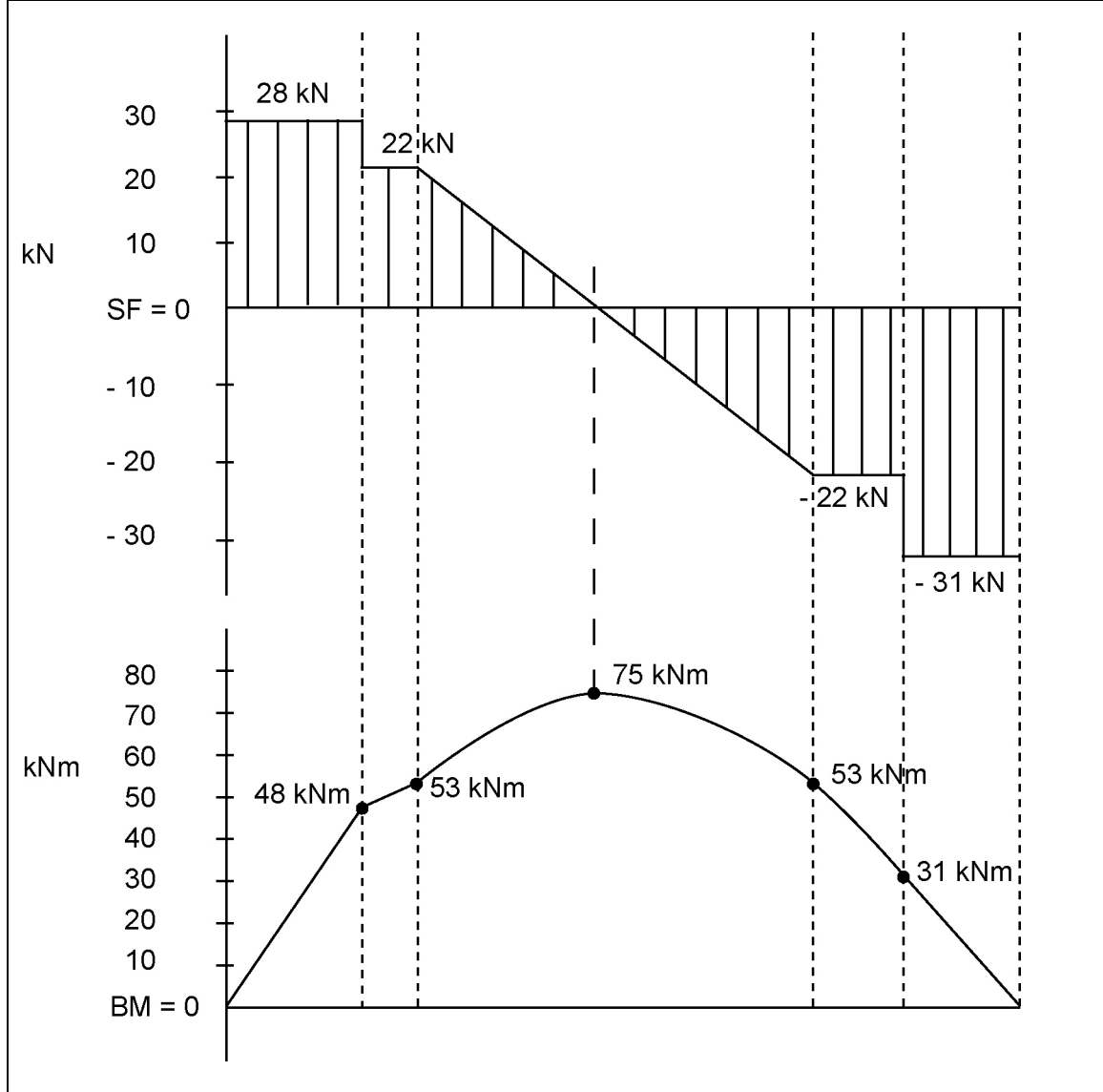

## Question 20

(18 marks)

- (a) Calculate the average acceleration of the plane as it travels along the runway from rest to take-off speed. (3 marks)

Description	Marks
$v = 300 \text{ km h}^{-1} = \frac{300}{3.6} = 83.3 \text{ m s}^{-1}$	1
$v_f^2 = v_i^2 + 2as \quad a = \frac{v_f^2 - v_i^2}{2s}$	1
$= \frac{83.3^2 - 0}{2 \times 3000} = 1.157 \text{ m s}^{-1}$	1
<b>Total</b>	<b>3</b>

- (b) Calculate the time that has elapsed when travelling from rest to take-off speed. (2 marks)

Description	Marks
$a = \frac{v_f - v_i}{\Delta t} \quad \Delta t = \frac{v_f - v_i}{a}$	1
$= \frac{83.3 - 0}{1.157} = 72.00 \text{ s}$	1
<b>Total</b>	<b>2</b>

- (c) The plane takes off at  $300 \text{ km h}^{-1}$  and continues to accelerate at  $1.2 \text{ m s}^{-2}$ . Calculate the time it will take for the plane to reach its cruising speed of  $900 \text{ km h}^{-1}$ . (3 marks)

Description	Marks
$300 \text{ km h}^{-1} = 83.3 \text{ m s}^{-1}, 900 \text{ km h}^{-1} = 250 \text{ m s}^{-1}$	1
$\Delta t = \frac{(250 - 83.3)}{1.2}$	1
$\Delta t = 138.9 \text{ s}$	1
<b>Total</b>	<b>3</b>

- (d) The plane has four engines, all producing an equal amount of thrust. Calculate the thrust provided by each engine when the plane begins to accelerate along the runway. (2 marks)

Description	Marks
Enters correct values into the equation	1
Calculates the correct answer	1
<b>Total</b>	<b>2</b>
$F = ma$ $= 560\,000 \times 1.157$ $= 647\,920 \text{ N}$ $\frac{647\,920}{4} = 162 \text{ kN per engine}$	

- (e) Using the table below, determine the runway length required if the fully loaded plane was leaving from an airstrip that was 4000 ft above sea level. (1 mark)

Description	Marks
3900 m ±100 m	1
<b>Total</b>	<b>1</b>

- (f) Calculate the weight of the plane as it is about to land. (3 marks)

Description	Marks
$323\ 000\ \text{l} \times 0.78 = 251\ 940\ \text{kg}$	1
$251\ 940 \times 0.8 = 201\ 552\ \text{kg used fuel}$	1
$560\ 000 - 201\ 552 = 358\ 448\ \text{kg landing weight}$	1
<b>Total</b>	<b>3</b>

- (g) Calculate how much work is done by the brakes on each of the 22 landing wheels to bring the plane to rest. (4 marks)

Description	Marks
$260\ \text{km h}^{-1} = 72.2\ \text{m s}^{-1}$	1
$E_K = \frac{1}{2} mv^2$ $= \frac{1}{2} \times 358\ 448 \times 72.2^2$ $= 934\ 266\ 036\ \text{J or } 934.3\ \text{MJ}$	1
$934.3 \times \frac{0.8}{22}$	1
$= 33.97\ \text{MJ per wheel}$	1
<b>Total</b>	<b>4</b>

Question 21

(23 marks)

- (a) Using the conditions of equilibrium, prove by calculation that the reaction forces at  $F_L$  and  $F_R$  are close to 360 kN and 315 kN respectively, due to the UDL and the loads imposed by the truck. Ignore the mass of the truss. (6 marks)

Description	Marks
$\sum M_{F_L} = (90 \times 10) + [(20 \times 9.8 - 90) \times 20] + \left(12 \times 40 \times \frac{40}{2}\right) - F_R \times 40 = 0$	1-2
$= 900 + 2120 + 9600 - 40F_R = 0$	1
$F_R = \frac{12\ 620}{40} = 315.5\ \text{kN}$	1
$\sum F_V = 315.5 - (20 \times 9.8) - (12 \times 40) + F_L = 0$	1
$F_L = 360.5\ \text{kN}$	1
<b>Total</b>	<b>6</b>

- (b) The truss has a section line running through AB, BC and CD. Neatly draw a free body diagram of the bridge to the right of the section line and indicate the assumed direction of the forces in the cut members of the truss. (4 marks)

Description	Marks
Indicates correct direction for BA	1
Indicates correct direction for BC	1
Indicates correct direction for DC	1
Indicates correct direction for $F_{UDL} + F_T$ at B	1
<b>Total</b>	<b>4</b>

- (c) Using moments around a suitable point in the truss, determine  $F_{AB}$ , the force in member AB, and state if it is in tension or compression. (5 marks)

Description	Marks
$\sum M_C = (106 \times 5) + (40 \times 12 \times 5) - (315.5 \times 25) - (F_{AB} \times 3) = 0$	1
$= 530 + 2400 - 7888 - 3F_{AB} = 0$	1
$3 F_{AB} = -4958 \quad F_{AB} = -1652.7 \text{ kN}$	1-2
negative – the initial assumption is incorrect member is in compression	1
<b>Total</b>	<b>4</b>

- (d) Using moments around a suitable point in the truss, determine  $F_{CD}$ , the force in member CD, and state if it is in tension or compression. (4 marks)

Description	Marks
$\sum M_B = - (315.5 \times 20) + (F_{CD} \times 3) = 0$	1
$= -6310 + 3F_{CD} = 0$	1
$F_{CD} = 2103.3 \text{ kN}$	1
positive – the initial assumption is correct member in tension	1
<b>Total</b>	<b>4</b>

- (e) Using any of the conditions of equilibrium, determine  $F_{BC}$ , the force in member BC, and state if it is in tension or compression. (4 marks)

Description	Marks
$\sum F_V = -106 - 480 + 315.5 - F_{BC} \sin(30.96) = 0$	1
$F_{BC} \sin(30.96) = -270.5$	1
$F_{BC} = 525.81 \text{ N}$	1
positive – initial assumption is correct member in tension	1
<b>Total</b>	<b>4</b>

## Question 22

(20 marks)

(a) Determine the stress and strain values in the table above.

(5 marks)

Description					Marks
For each Force (N) column					
Determines the correct stress and strain values in the table					1–5
<b>Total</b>					<b>5</b>
Force (N)	173	298	440	471	455 (Failure)
Stress (N mm <sup>-2</sup> )	<b>55.1</b>	<b>94.9</b>	<b>140.1</b>	<b>149.9</b>	<b>144.8</b>
Extension (mm)	0.055	0.095	0.210	0.280	0.420
Strain	<b>0.00079</b>	<b>0.00136</b>	<b>0.00300</b>	<b>0.00400</b>	<b>0.00600</b>

(b) On the grid below, graph the tensile test results, draw the curve of best fit and label the following:

- (i) elastic limit
- (ii) yield point
- (iii) part of the line where permanent plastic deformation is occurring
- (iv) ultimate tensile strength (UTS).

(6 marks)

Description	Marks
Plots points correctly	1
Draws the curve of best fit	1
Locates and labels elastic limit correctly	1
Locates and labels yield point correctly	1
Locates and labels line of permanent plastic deformation correctly	1
Locates and labels UTS correctly	1
<b>Total</b>	<b>6</b>

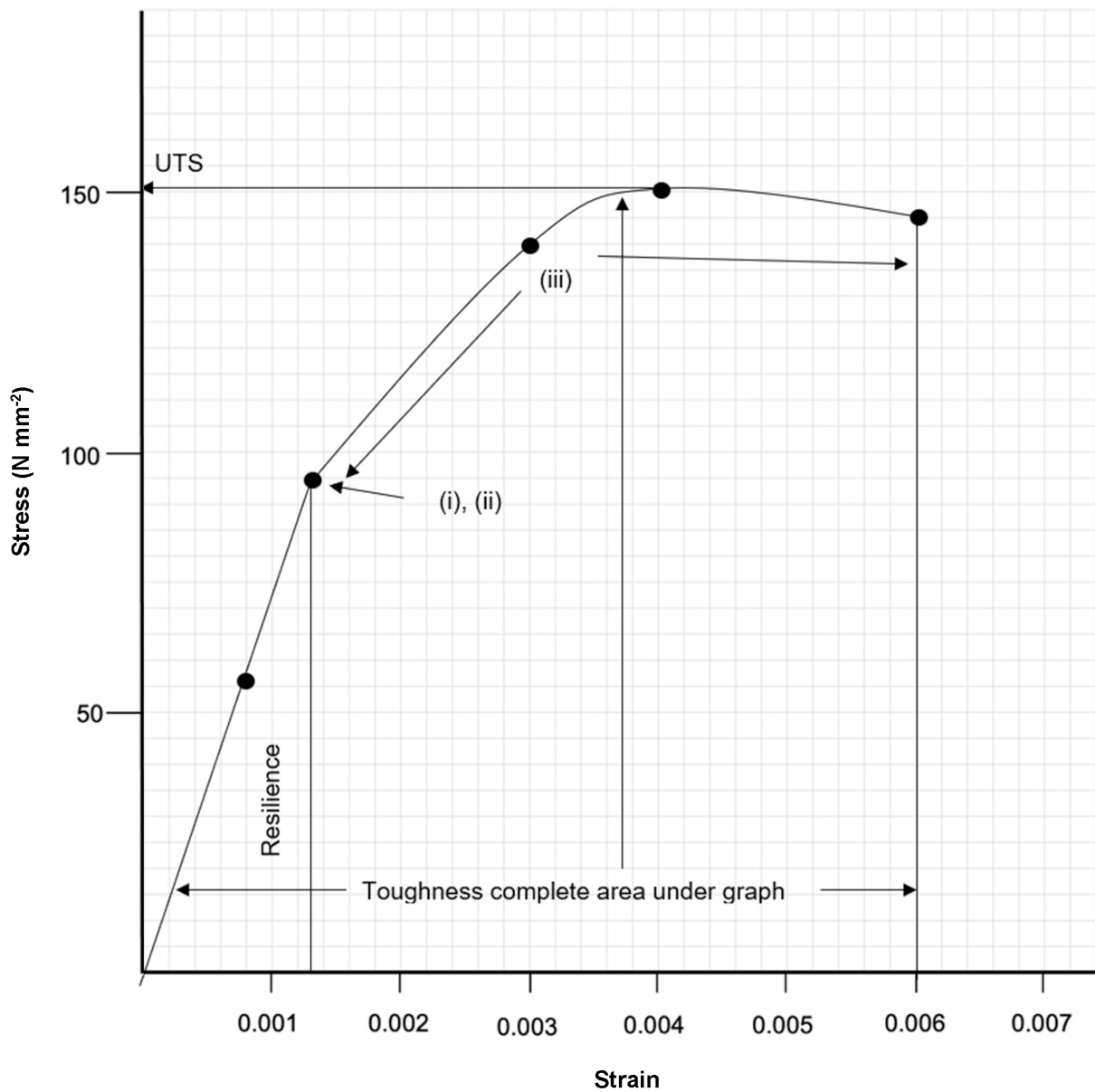

## Question 22 (continued)

- (c) Determine Young's Modulus for the material using the stress-strain graph in part (b) on page 41. (2 marks)

Description	Marks
Uses the gradient of the graph in the proportional section	1
$\text{Gradient} = \frac{70 - 0}{0.001 - 0}$ $= 70\,000 \text{ MPa}$	1
<b>Total</b>	<b>2</b>

- (d) Identify the material based on the data collected. Justify your answer. (3 marks)

Description	Marks
aluminium	1
Any two of	
E is close to 70 000 MPa	1–2
UTS is close to 150 MPa	
yield stress is close to 95 MPa	
<b>Total</b>	<b>3</b>

- (e) Show the part of the graph that indicates the toughness of the material. (1 mark)

Description	Marks
Shades toughness correctly	1
<b>Total</b>	<b>1</b>

- (f) Show the part of the graph that indicates the resilience of the material. (1 mark)

Description	Marks
Shades resilience correctly	1
<b>Total</b>	<b>1</b>

- (g) Identify whether the material exhibits ductile **or** brittle behaviour. Justify your answer. (2 marks)

Description	Marks
ductile	1
graph shows considerable extension under tensile force	1
<b>Total</b>	<b>2</b>



## Section Three: Mechatronics

50% (98 Marks)

## Part A:

10% (12 Marks)

## Question 23

(2 marks)

Determine the capacitance between nodes A and B when the switch is open.

Description	Marks
$\frac{1}{C_T} = \frac{1}{C_2} + \frac{1}{C_4}$	
$\frac{1}{C_T} = \frac{1}{0.2} + \frac{1}{0.5}$	1
$C_T = 0.143 \mu\text{F}$	1
<b>Total</b>	<b>2</b>

## Question 24

(2 marks)

A USB umbilical can supply a maximum current of 90 mA. Calculate the charge (in C) it can supply a device in every hour of use.

Description	Marks
Converts mA to A	1
Calculates the correct final answer	1
<b>Total</b>	<b>2</b>
Calculate charge using $q = It$ $q = \frac{90}{1000} \times (60 \times 60) = 324 \text{ C}$	

## Question 25

(2 marks)

A ceramic capacitor has 155K stamped on its side. State the capacitance of this capacitor in nF.

Description	Marks
$155 = 1\,500\,000 \text{ pF}$	
$155\text{K} = 1\,500\,000\,000 \text{ pF}$	1
$= 1\,500\,000 \text{ nF}$	1
<b>Total</b>	<b>2</b>

**Question 26****(2 marks)**

An E12 resistor is required for a circuit to have a resistance of 4.7 k $\Omega$  and a tolerance of 2%. State the colours of the four bands.

Description	Marks
Band one: yellow	1–2
Band two: violet	
Band three: red	
Band four: red	
<b>Total</b>	<b>2</b>
Note: One mark off for each incorrect answer.	

**Question 27****(2 marks)**

A bipolar NPN transistor has a DC current gain,  $\beta$  value, of 200. Calculate the minimum base current ( $I_B$ ) required to place the transistor into saturation mode when a collecting current of 4 mA is applied.

Description	Marks
$\beta = \frac{I_C}{I_B}$	
$I_B = \frac{I_C}{\beta} = \frac{4}{200}$	1
$= 0.02 \text{ mA or } 2 \times 10^{-5} \text{ A}$	1
<b>Total</b>	<b>2</b>

**Question 28****(2 marks)**

Describe the likely consequence of using two 100  $\Omega$  resistors, each with a power rating of 0.5 W, arranged in parallel that are being supplied a by 6 V DC cell.

Description	Marks
as P in each resistor = $\frac{(6)^2}{100} = 0.36 \text{ W}$ that is greater than the 0.5 W power rating	1
no consequence	1
<b>Total</b>	<b>2</b>

## Part B:

40% (86 Marks)

## Question 29

(14 marks)

- (a) For the circuit on page 48, use Kirchhoff's Current Law (KCL) to complete the table by determining the current for  $i_3$ ,  $i_4$ ,  $i_6$  and  $i_7$ . The values for  $i_1$ ,  $i_2$  and  $i_5$  are given in the table below. (4 marks)

Description		Marks
Calculates correct values		1-4
<b>Total</b>		<b>4</b>
	Current (A)	Working
$i_1$	10 A	
$i_2$	- 6 A	
$i_3$	2	At node 'B', utilising KCL, $i_2 = i_3 + i_5$ or, $i_3 = i_2 - i_5 = 6 - 4 = 2$ A i.e. $i_3 = 2$ A
$i_4$	4	At node 'A', from KCL, $i_1 = i_2 + i_4$ $10 = 6 + i_4$ or $i_4 = 4$ A
$i_5$	4 A	
$i_6$	6	Similarly, at node 'C', $i_7 = i_5 + i_6$ giving $i_6 = i_7 - i_5 = 10 - 4 = 6$ A Therefore $i_6 = 6$ A
$i_7$	10	$i_1 = i_7$ Therefore $i_7 = 10$ A
		Then, all the unknown currents of the problem being determined, the branch currents become $i_1 = i_7 = 10$ A $i_2 = 6$ A $i_3 = 2$ A $i_4 = 4$ A $i_5 = 4$ A $i_6 = 6$ A

## Question 29 (continued)

- (b) (i) Prove by calculation that the total resistance of the circuit is 330
- $\Omega$
- . (2 marks)

Description	Marks
$R_T = 100 + \left(\frac{1}{120} + \frac{1}{40}\right)^{-1} + \left(\frac{3}{60}\right)^{-1} + 80 + 100$	1
$= 100 + 30 + 20 + 80 + 100 = 330 \Omega$	1
<b>Total</b>	<b>2</b>

- (ii) Calculate the maximum current in the circuit if there is a 10% fluctuation in the battery voltage. (2 marks)

Description	Marks
10% fluctuation = $18 \times 0.1 = 1.8 \text{ V}$	1
$I = \frac{V}{R_T} = \frac{18 + 1.8}{330} = \frac{19.8}{330} = 0.06 \text{ A (or 60 mA)}$	1
<b>Total</b>	<b>2</b>

- (iii) A multimeter used to determine the current through the 60
- $\Omega$
- resistor (R4) displayed 18.2 mA. Prove by calculation that this reading is correct. (2 marks)

Description	Marks
$I = \frac{V}{R_T} = \frac{18}{330} = 54.5 \text{ mA}$	1
$I_4 = \frac{1}{3} \times I_T = \frac{1}{3} \times 54.5 = 18.2 \text{ mA}$	1
<b>Total</b>	<b>2</b>

- (iv) Each of the 60
- $\Omega$
- resistors are tungsten filament globes. Determine the power dissipated in each globe. (2 marks)

Description	Marks
$P = I^2 \times R$	
$= (18.2)^2 \times 60 = 19.9 \text{ mW}$ or $V = IR = 18.2 \times 60 = 1.092 \text{ V}$	
then, $P = \frac{V^2}{R} = \frac{1.092^2}{60} = 0.0199 \text{ W} = 19.9 \text{ mW}$	1-2
<b>Total</b>	<b>2</b>
Note: Must identify Watts (or milliWatts) as unit of power	

- (v) If R4 blows, describe the effect on the other two globes, R5 and R6. (2 marks)

Description	Marks
they both stay on	1
both get brighter	1
<b>Total</b>	<b>2</b>

Question 30

(19 marks)

- (a) On the excerpt below, from the above diagram, show the direction of conventional current between Points A and B when switch  $S_1$  is closed. (1 mark)

Description	Marks
	1
<b>Total</b>	<b>1</b>

- (b) State what the abbreviation 'DPDT' stands for and the function of the DPDT switch in the circuit above. (2 marks)

Description	Marks
double pole double throw	1
reverse direction of motor (or current)	1
<b>Total</b>	<b>2</b>

- (c) State the value expected to be seen on the multimeter display for each of the following selected pairs of pins as the motor operates. (2 marks)



Description	Marks
Pins 1 and 8: 12 V	1
Pins 2 and 6: 0 V	1
<b>Total</b>	<b>2</b>

- (d) State **two** possible consequences if  $C_4$  was short circuited. (2 marks)

Description	Marks
Any two of	
<ul style="list-style-type: none"> <li>• the motor and the LEDs will not operate</li> <li>• the fuse would blow</li> <li>• there should be no damage to any other part of the circuit the motor and the LEDs will not operate.</li> </ul>	1-2
<b>Total</b>	<b>2</b>

Question 30 (continued)

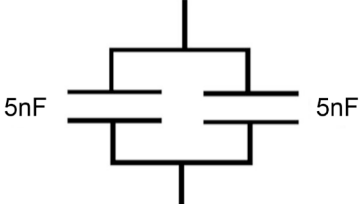
- (e) For each of the **two** solutions, draw circuit diagrams and show appropriate calculations of how 5 nF or 20 nF capacitors could be used to take the place of the 10 nF capacitor. (4 marks)

Description	Marks
 	1-2
$C_T = 5 + 5 = 10$ $C_T = \frac{20}{2} = 10 \text{ nF}$ or $\frac{1}{C_T} = \frac{1}{20} + \frac{1}{20}$	1-2
<b>Total</b>	<b>4</b>

- (f) (i) Prove by calculation that the current through the motor is 0.2 A. (2 marks)

Description	Marks
$P = VI$ $I = \frac{P}{V}$	
$= \frac{2.4}{12}$	1
$= 0.2 \text{ A}$	1
<b>Total</b>	<b>2</b>

- (ii) Prove by calculation that the current through R<sub>4</sub> is 0.01 A if the LED consumes 2 V. (2 marks)

Description	Marks
$V_{R4} = 12 - 2$ $= 10 \text{ V}$	1
$I_{R4} = \frac{10}{1000}$ $= 0.01 \text{ A}$	1
<b>Total</b>	<b>2</b>

- (iii) Prove by calculation that the collector current of the transistor is 0.21 A. (1 mark)

Description	Marks
$I_{ce} = I_{motor} + I_{R4}$ $= 0.2 + 0.01$ $= 0.21 \text{ A}$	1
<b>Total</b>	<b>1</b>

- (iv) With 5 V out of Pin 3, prove by calculation that the transistor is in saturation mode. (3 marks)

Description	Marks
$5 - 0.7 - V_{R2} = 0$ $I_{R2} = \frac{4.3}{1000}$ $I_{R2} = 0.0043 \text{ A}$	1
$\frac{I_C}{I_B} = \frac{0.21}{0.0043}$ $= 49$	1
49 is less than 50, therefore in saturation	1
<b>Total</b>	<b>3</b>

## Question 31

(21 marks)

- (a) Explain the operation of the circuit shown above as the temperature in the room increases. Include reference to the resistance of the thermistor and the voltage  $V_{in}$  as the temperature increases. (4 marks)

Description	Marks
resistance of thermistor decreases	1
$V_{in}$ increases	1
transistor then switches on/becomes saturated/ $V_{BE} = 0.7 \text{ V}$	1
and motor then switches on	1
<b>Total</b>	<b>4</b>

- (b) Calculate the resistance R when  $V_{in}$  is 4.5 V. (3 marks)

Description	Marks
$V_1 = 6.0 - 4.5 = 1.5 \text{ V}$	1
$\frac{R}{16\text{k}} = \frac{1.5}{4.5}$	1
$R = 0.333 \times 16000 \text{ V}$ $R = 5333 \Omega$ $R = 5.33 \text{ k}\Omega$	1
<b>Alternate working:</b>	
$V_2 = IR_2$ $I = \frac{V_2}{R_2}$ $I = \frac{4.5}{16\ 000 \text{ k}}$ $I = 0.281 \text{ mA}$	1
$V_1 = 6.0 - 4.5 = 1.5 \text{ A}$	1
$V_1 = IR_1$ $R_1 = \frac{V_1}{I}$ $R_1 = \frac{1.5}{0.000281} = 5333 \Omega$ $R_1 = 5.33 \text{ k}\Omega$	1
<b>Total</b>	<b>3</b>

- (c) State how the input sensing circuit could be easily altered to allow the operator to set the temperature at which the fan motor switches on. (1 mark)

Description	Marks
replace fixed resistor with a variable resistor or add a variable resistor	1
<b>Total</b>	<b>1</b>



- (d) Using a type 4 thermistor, show on the graph that: (2 marks)
- (i) the resistance at -20 °C is 500 kΩ
  - (ii) the temperature that gives 3 kΩ of resistance is 110 °C.

Description	Marks
lines from each axis on graph or a visible X	1-2
<b>Total</b>	<b>2</b>

- (e) Show that the maximum and minimum expected  $V_{in}$  are approximately 5 V and 0.2 V, respectively. (4 marks)

Description	Marks
At -20 °C, resistance from graph is 500 kΩ	
$V_{in} = V_{CC} \times \frac{R_1}{R_{NTC} + R_1}$ $V_{in} = \frac{6 \times 16}{500 + 16}$ $V_{in} = \frac{96}{516}$ $V_{in} = 0.186 \text{ V (0.2 V)}$	1-2
At 110 °C, resistance from graph is 3 kΩ	
$V_{in} = V_{CC} \times \frac{R_1}{R_{NTC} + R_1}$ $V_{in} = \frac{6 \times 16}{3 + 16}$ $V_{in} = \frac{96}{19}$ $V_{in} = 5.05 \text{ V (5 V)}$	1-2
<b>Total</b>	<b>4</b>

- (f) Determine, to the nearest mV, the digital resolution voltage of the analogue to digital converter (ADC). (3 marks)

Description	Marks
$V_{Ref} = \frac{6}{2^n - 1}$	1
$= \frac{6}{255}$	
$= 0.023 \text{ V}$	1
$= 23 \text{ mV}$	1
<b>Total</b>	<b>3</b>

**Question 31** (continued)

(g) Calculate the decimal digital output of the analogue to digital converter (ADC) when the input is:

(i) 0.2 V

(ii) 5 V.

(4 marks)

Description	Marks
Using 0.2 V and 5 V	
$\text{min digital output} = \frac{\text{min analogue output}}{\text{digital resolution voltage}}$ $\text{min digital output} = \frac{0.2}{0.023}$ $\text{min digital output} = 9 \text{ (8.7)}$	1-2
$\text{max digital output} = \frac{\text{min analogue output}}{\text{digital resolution voltage}}$ $\text{max digital output} = \frac{5}{0.023}$ $\text{max digital output} = 217$	1-2
<b>Total</b>	<b>4</b>
Note: Must be written as whole numbers; maximum of 3 marks if not in whole numbers.	

## Question 32

(32 marks)

- (a) Using a universal system block diagram for only the conveyor, list the components of the checkout system operating in 'Auto Mode' and 'Manual Mode'. This should include all the real-world inputs and outputs that are processed or produced by the conveyor. (6 marks)

Description	Marks
Inputs: any three of	
<ul style="list-style-type: none"> <li>• item sensed</li> <li>• manual button pushed</li> <li>• electric energy</li> <li>• foot pedal</li> </ul>	1–3
Outputs: any three of	
<ul style="list-style-type: none"> <li>• heat</li> <li>• sound</li> <li>• movement</li> <li>• light</li> </ul>	1–3
<b>Total</b>	<b>6</b>

- (b) Draw a flow chart for the checkout conveyor and scanning when operating in both modes. Use the standard flow chart symbols shown in the Data Book. (14 marks)

Description	Marks
Initialise motor off	1
Check toggle switch	1
Manual mode if toggle is 'yes'	1
Check foot pedal	1
Motor off if foot pedal is 'no'	1
Motor on if foot pedal is 'yes'	1
Automatic mode if toggle is 'no'	1
Check far sensor	1
Then check near sensor	1
Then if far sensor is 'yes' and near sensor is 'no', turn motor on	1
Check override switch	1
Motor remains on until near sensor is 'yes'	1
Turn motor off if far sensor is 'no', near sensor is 'yes' and override is 'yes'	1
Uses standard flow chart symbols	1
<b>Total</b>	<b>14</b>

Question 32 (continued)

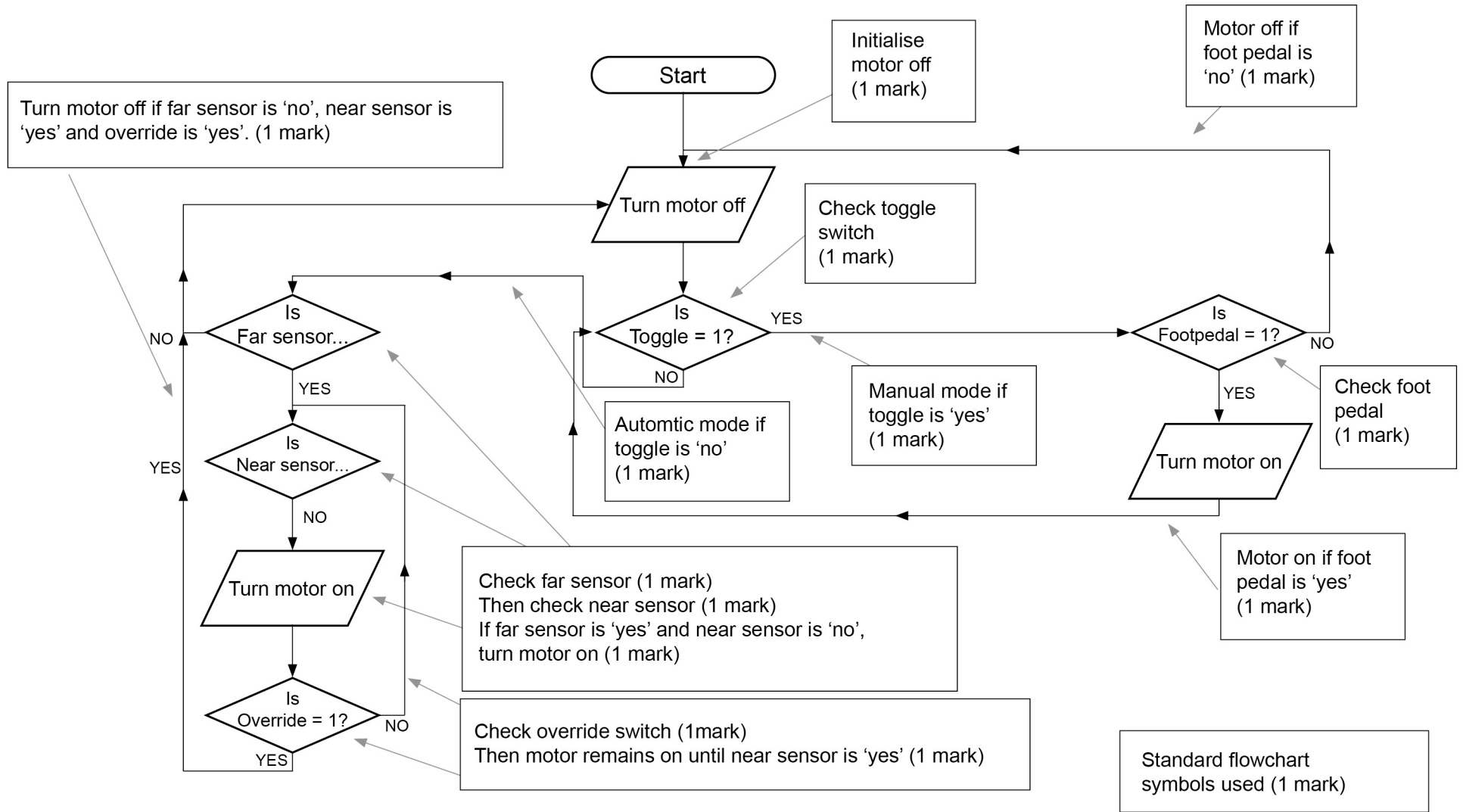

- (c) Use this specific application to describe and give an example of both an open-loop and a closed-loop system. (4 marks)

Description	Marks
<b>Open-loop</b>	
sensors detect an outcome and feeds that make to a comparison (or decision) that will then lead to a programmed action	1
example: sensors detecting items and turning conveyor motor on/off or sensors identifying item, checking in database and selecting the type of light and sound	1
<b>Subtotal</b>	<b>2</b>
<b>Closed-loop</b>	
no monitoring (sensing) and the operation continuing	1
example: when in manual mode the conveyor will keep on moving regardless of any item on it or if they are in the store's inventory database	1
<b>Subtotal</b>	<b>2</b>
<b>Total</b>	<b>4</b>

- (d) Design a control circuit which meets the brief listed above. (8 marks)

Description	Marks
Base resistor connected from output of microcontroller transistor	1
Transistor connected to relay and ground	1
Relay coil correctly connected to transistor and 5 V	1
Relay diode correctly connected with correct polarity	1
Relay correct connection to 36 V	1
Motor connected correctly	1
SPST switch connected correctly in series with 36 V supply	1
All circuit symbols drawn correctly	1
<b>Total</b>	<b>8</b>

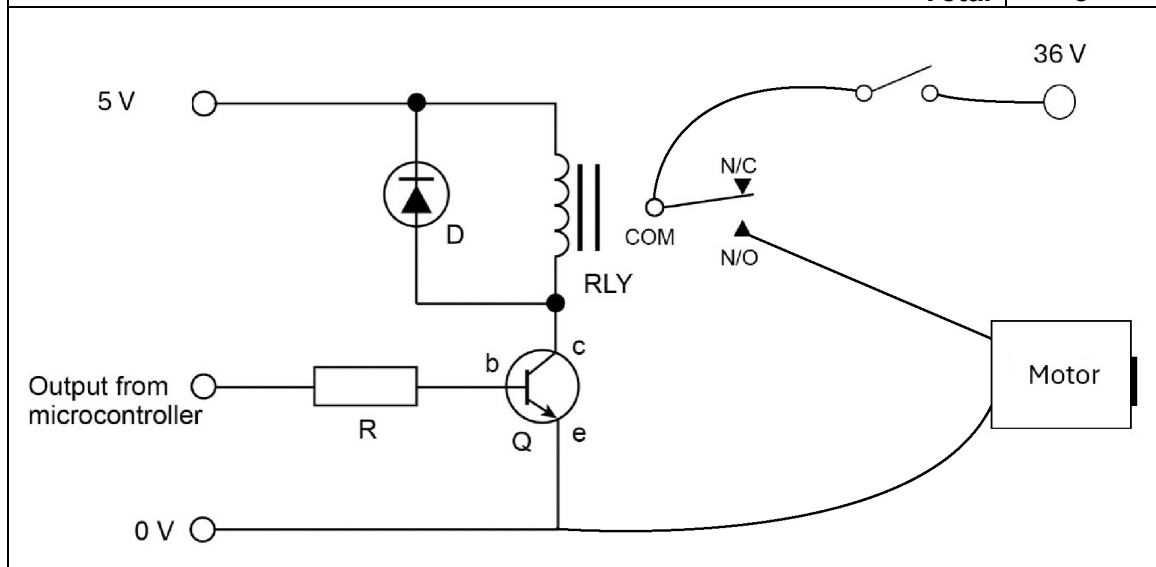

**Copyright**

© School Curriculum and Standards Authority, 2024

This document – apart from any third party copyright material contained in it – may be freely copied, or communicated on an intranet, for non-commercial purposes in educational institutions, provided that it is not changed and that the School Curriculum and Standards Authority (the Authority) is acknowledged as the copyright owner, and that the Authority's moral rights are not infringed.

Copying or communication for any other purpose can be done only within the terms of the *Copyright Act 1968* or with prior written permission of the Authority. Copying or communication of any third party copyright material can be done only within the terms of the *Copyright Act 1968* or with permission of the copyright owners.

Any content in this document that has been derived from the Australian Curriculum may be used under the terms of the Creative Commons [Attribution 4.0 International \(CC BY\)](https://creativecommons.org/licenses/by/4.0/) licence.

An *Acknowledgements variation* document is available on the Authority website.

*Published by the School Curriculum and Standards Authority of Western Australia  
303 Sevenoaks Street  
CANNINGTON WA 6107*