



ATAR course examination, 2022

PHYSICAL EDUCATION STUDIES

Practical (performance) examination Volleyball

Time allowed

Preparation: 30 minutes
Examination: 60 minutes (30 minute performance)

Materials required

To be provided at the venue

Non-personal equipment required for Volleyball

To be provided by the candidate

Non-marking athletic shoes

Structure of the examination

The Physical Education Studies ATAR course examination consists of a written component and a practical (performance) component.

Criteria for marking the practical (performance) examination

Criteria	Marks available	Percentage of practical examination
Skills performance	30	50
Conditioned performance	20	50
Total		100

Instructions to candidates

1. You are required to wear clothing and personal playing and safety equipment that is approved for competition by the sport's governing body.
2. Clothing must not identify you, your school, club or achievements, and it is requested that you wear black, navy or a white shirt for the examination.
3. You are required to report to a supervisor to register for the practical examination 40 minutes before your scheduled examination time.
4. Once your attendance has been recorded you will be given a coloured, numbered bib to wear for the examination and you will be directed to a supervised warm-up area.
5. Just prior to the scheduled examination time you will be escorted from the warm-up area to the examination area.
6. You must follow the requirements for this examination published in the *Physical Education Studies ATAR course Practical (performance) examination requirements 2022* document.

SECTION ONE – Skills Performance

1. Skills set

(30 marks)

Skill 1	Skill 2	Skill 3	Skill 4	Skill 5
Forearm pass: serve reception	Front set	Spike	Block	Overhead float serve

Drill #1: Forearm pass: serve reception, Front set

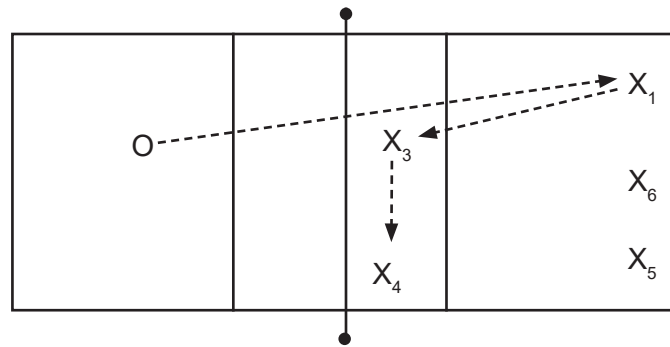

- Key:**
- X = player
 - O = feeder
 - > = player movement
 - > = feeder movement
 - - - - -> = ball movement

Drill description:

1. Feeder O serves the ball into the area where there are three passers (X₁ X₆ X₅).
2. Players forearm pass the ball to the setter X₃.
3. Setter sets the ball to player or X₄ who catches and returns the ball to the feeder O.

Drill #2: Spike

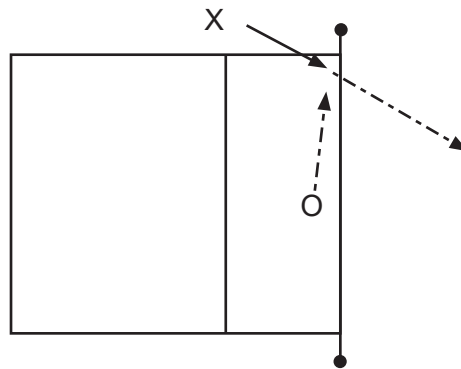

- Key:**
- X = player
 - O = feeder
 - > = player movement
 - > = feeder movement
 - - - - -> = ball movement

Drill description:

1. Feeder O stands in position 3 and throws a ball up that resembles a high outside set.
2. Players are lined up outside the court ready to spike the ball from position 4.
3. Player X spikes the ball and then the retriever returns the ball back to the feeder.
4. Drill may be performed from position 2 for left handed players.

Drill #3: Block

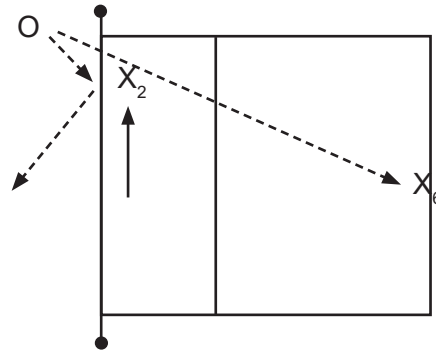

- Key:**
- X = player
 - O = feeder
 - ▶ = player movement
 - ▶ = feeder movement
 - - - - -▶ = ball movement

Drill description:

1. Feeder stands on a jump box just outside the court next to position 4.
2. Player X₂ stands in position 2 on the other side of the net ready to block the spiked ball that is hit by the feeder.
3. Feeder spikes a driven ball toward player X₂ towards position X₆.
4. Player X₂ attempts to block the ball back into court.

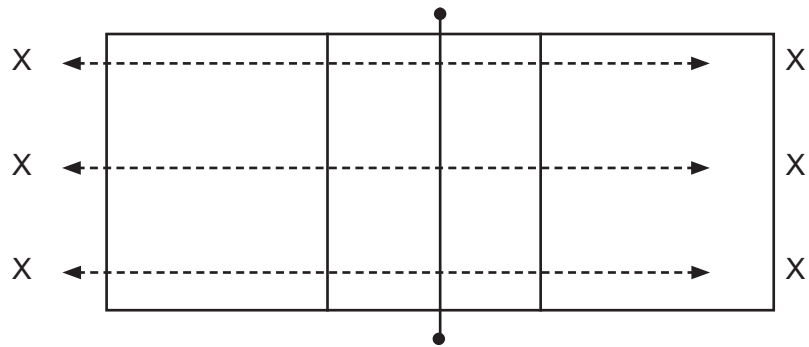
Drill #4: Overhead float serve

Key:

- X = player
- > = player movement
- > = feeder movement
- > = ball movement

Drill description:

1. Players are to serve over the net demonstrating the overhead float.
2. Players on opposite side stand outside of the court and roll the ball back to the servers.

This page has been left blank intentionally

This page has been left blank intentionally

This page has been left blank intentionally

This document – apart from any third party copyright material contained in it – may be freely copied, or communicated on an intranet, for non-commercial purposes in educational institutions, provided that it is not changed and that the School Curriculum and Standards Authority (the Authority) is acknowledged as the copyright owner, and that the Authority's moral rights are not infringed.

Copying or communication for any other purpose can be done only within the terms of the *Copyright Act 1968* or with prior written permission of the Authority. Copying or communication of any third party copyright material can be done only within the terms of the *Copyright Act 1968* or with permission of the copyright owners.

Any content in this document that has been derived from the Australian Curriculum may be used under the terms of the Creative Commons [Attribution 4.0 International \(CC BY\)](https://creativecommons.org/licenses/by/4.0/) licence.

An *Acknowledgements variation* document is available on the Authority website.

<p><i>Published by the School Curriculum and Standards Authority of Western Australia 303 Sevenoaks Street CANNINGTON WA 6107</i></p>
