



MATHEMATICS SPECIALIST

Calculator-assumed

ATAR course examination 2024

Marking key

Marking keys are an explicit statement about what the examining panel expect of candidates when they respond to particular examination items. They help ensure a consistent interpretation of the criteria that guide the awarding of marks.

Question 9

(6 marks)

Consider the complex equation $z^n = 1$ where n is a positive integer.

- (a) Show that $z = \frac{1+i}{\sqrt{2}}$ will be a solution of $z^{24} = 1$. (2 marks)

Solution
$\left(\frac{1+i}{\sqrt{2}}\right)^{24} = \left(\text{cis}\left(\frac{\pi}{4}\right)\right)^{24} = \text{cis}\left(\frac{24\pi}{4}\right) = \text{cis}(6\pi) = 1$
<p>Hence as $\left(\frac{1+i}{\sqrt{2}}\right)^{24} = 1$, then $z = \frac{1+i}{\sqrt{2}}$ is a solution of $z^{24} = 1$</p>
Specific behaviours
<ul style="list-style-type: none"> ✓ converts correctly to polar form ✓ states that $\left(\frac{1+i}{\sqrt{2}}\right)^{24} = \text{cis}(6\pi)$

Alternative Solution
<p>Substituting $z = \frac{1+i}{\sqrt{2}}$ directly using CAS: $\left(\frac{1+i}{\sqrt{2}}\right)^{24} = \frac{4096}{2^{12}} = 1$</p>
<p>Hence as $\left(\frac{1+i}{\sqrt{2}}\right)^{24} = 1$, then $z = \frac{1+i}{\sqrt{2}}$ is a solution of $z^{24} = 1$</p>
Specific behaviours
<ul style="list-style-type: none"> ✓ substitutes $z = \frac{1+i}{\sqrt{2}}$ into the equation correctly ✓ states that $\left(\frac{1+i}{\sqrt{2}}\right)^{24} = \frac{4096}{2^{12}}$

- (b) Determine all the values of n so that $z = \frac{1+i}{\sqrt{2}}$ is a solution of $z^n = 1$. (2 marks)

Solution
$\left(\frac{1+i}{\sqrt{2}}\right)^n = \left(\text{cis}\left(\frac{\pi}{4}\right)\right)^n = \text{cis}(2\pi k) \quad k = 1, 2, 3, \dots$
$\therefore \text{cis}\left(\frac{n\pi}{4}\right) = \text{cis}(2\pi k) \quad \therefore \frac{n\pi}{4} = 2\pi k \quad \dots (1)$
$\text{i.e. } n = 8k$
<p>Hence $n = 8, 16, 24, 32, \dots$</p>
Specific behaviours
<ul style="list-style-type: none"> ✓ forms the correct statement relating n and k (statement 1) ✓ states the set of possible values for n

Consider the smallest value of n from part (b).

- (c) Explain how you could locate all the solutions to the equation $z^n = 1$ in the Argand plane for this smallest value of n . (2 marks)

Solution
All solutions of $z^8 = 1$ are located on a circle with radius of ONE unit. To locate the other solutions (from $z = \frac{1+i}{\sqrt{2}}$), rotate an angle of $\frac{\pi}{4}$ around the circle, since the solutions are equally spaced around this circle.
Specific behaviours
✓ states that all solutions are located on a circle of radius 1
✓ states that the solutions are equally separated by an angle of $\frac{\pi}{4}$ or 45°

Question 10

(8 marks)

(a) A circle is drawn in the Argand plane. Let z be any point on this circle.

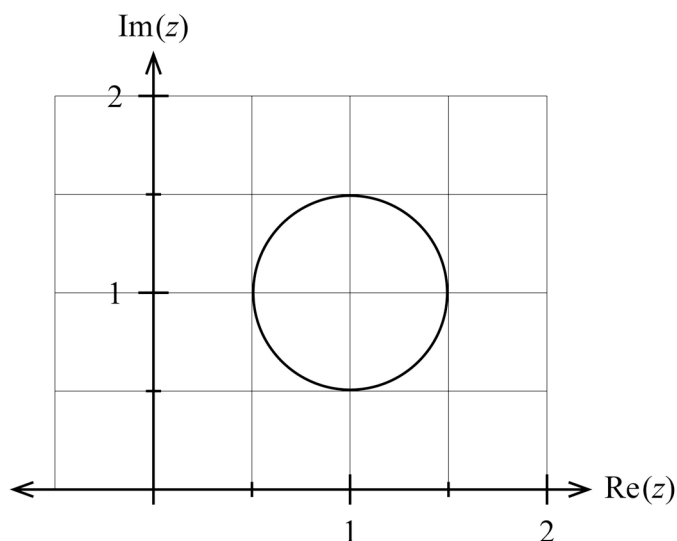

(i) State the equation for this circle. (2 marks)

Solution
Equation of the circle is $ z - (1 + i) = \frac{1}{2}$
Specific behaviours
<ul style="list-style-type: none"> ✓ writes an equation where the modulus is equal to $\frac{1}{2}$ ✓ writes an equation using the correct centre point

(ii) Given that $a \leq |z - i| \leq b$, determine the exact values for a and b . (2 marks)

Solution
The statement $a \leq z - i \leq b$ can be interpreted as what are the minimum and maximum values for the distance of z from $(0, 1)$.
From the Argand diagram the closest distance to the circle from $(0, 1)$ is $\frac{1}{2}$.
The greatest distance from $(0, 1)$ is $\frac{3}{2}$.
Hence $a = \frac{1}{2}$ and $b = \frac{3}{2}$.
Specific behaviours
<ul style="list-style-type: none"> ✓ indicates distances from $(0, 1)$ to the circle ✓ states the correct values for a and b

(b) Sketch, on the Argand diagram below, the locus given by the intersection of:

$$z - \bar{z} \leq 6i \quad \text{and} \quad \frac{\pi}{4} \leq \text{Arg}(z - 1 + i) \leq \frac{3\pi}{4}. \quad (4 \text{ marks})$$

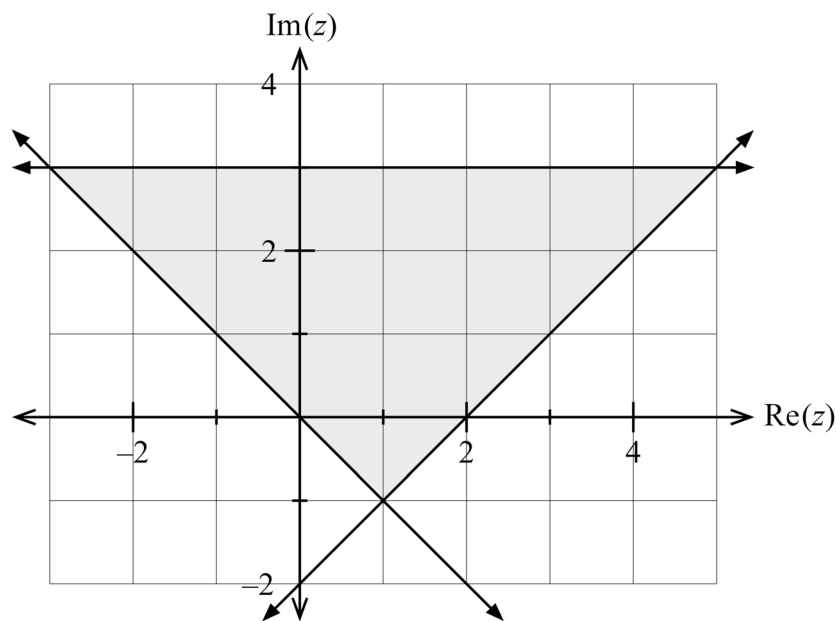

Solution
$z - \bar{z} \leq 6i$ i.e. $2\text{Im}(z)i \leq 6i$ i.e. $\text{Im}(z) \leq 3$ $\frac{\pi}{4} \leq \text{Arg}(z - 1 + i) \leq \frac{3\pi}{4}$ means that the argument from $z = 1 - i$ is between $\frac{\pi}{4}$ and $\frac{3\pi}{4}$ inclusive.
We then consider the INTERSECTION of these two regions. Shown on diagram above.
Specific behaviours
<ul style="list-style-type: none"> ✓ obtains $\text{Im}(z) \leq 3$ from $z - \bar{z} \leq 6i$ ✓ indicates the boundary $\text{Im}(z) = 3$ ✓ indicates the boundaries $\text{Im}(z) = -\text{Re}(z)$ and $\text{Im}(z) = \text{Re}(z) - 2$ ✓ indicates the shaded region correctly

Question 11

(6 marks)

Scrummy Donuts are modelled by the circular region bounded by the circle $(x-3)^2 + y^2 = 4$ being rotated about the y axis to produce a donut-shaped object called a torus. All dimensions are in centimetres.

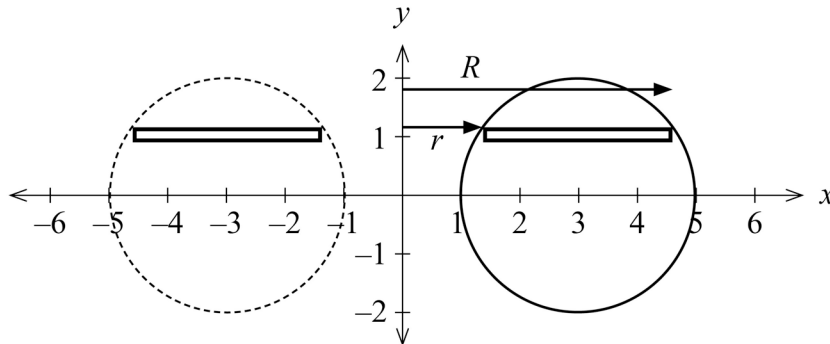

(a) Show that the volume of this donut is given by $\int_a^b 12\pi\sqrt{4-y^2} dy$.

State the values for a and b .

(4 marks)

Solution	
From equation of the circle: $(x-3)^2 = 4 - y^2$ i.e. $x-3 = \pm\sqrt{4-y^2}$	
i.e. $x = 3 \pm \sqrt{4-y^2}$ $\therefore R = 3 + \sqrt{4-y^2}$ $r = 3 - \sqrt{4-y^2}$	
$dV = \pi \int (R^2 - r^2) dy$	
$R^2 = (3 + \sqrt{4-y^2})^2 = 9 + 6\sqrt{4-y^2} + (4-y^2) = 13 + 6\sqrt{4-y^2} - y^2$	
$r^2 = (3 - \sqrt{4-y^2})^2 = 9 - 6\sqrt{4-y^2} + (4-y^2) = 13 - 6\sqrt{4-y^2} - y^2$	
$\therefore R^2 - r^2 = 12\sqrt{4-y^2}$	
$\therefore V = \int_{-2}^2 12\pi\sqrt{4-y^2} dy$ i.e. $a = -2, b = 2$.	
Specific behaviours	
<ul style="list-style-type: none"> ✓ re-writes the equation of the circle correctly in terms of the x value ✓ writes the correct expression for r and R in terms of x ✓ develops the correct expression for the integrand ✓ states the correct values for a, b 	

Alternative Solution
<p>From equation of the circle: $(x-3)^2 = 4-y^2$ i.e. $x-3 = \pm\sqrt{4-y^2}$ i.e. $x = 3 \pm \sqrt{4-y^2}$ $\therefore R = 3 + \sqrt{4-y^2}$ $r = 3 - \sqrt{4-y^2}$ Volume of the thin disk with height dy $dV = \pi(R^2 - r^2)dy = \pi(R+r)(R-r)dy = \pi(6)(2\sqrt{4-y^2})dy = 12\pi\sqrt{4-y^2} dy$ $\therefore V = \int_{-2}^2 12\pi\sqrt{4-y^2} dy$ i.e. $a = -2, b = 2$.</p>
Specific behaviours
<ul style="list-style-type: none"> ✓ re-writes the equation of the circle correctly in terms of the x value ✓ writes the correct expression for r and R in terms of x ✓ develops the correct expression for the integrand ✓ states the correct values for a, b

Nutritional information about Scrummy Donuts*: Average density = 0.28 g/cm³

Health recommendation: No more than 180 g to be eaten per day. (*eat responsibly)

- (b) Calculate the maximum number of Scrummy Donuts that can be eaten each day, if the health recommendation is to be followed. (2 marks)

Solution
<p>Volume = $\int_{-2}^2 12\pi\sqrt{4-y^2} dy = \pi(75.3982...) = 236.8705... \text{ cm}^3$ Mass of one donut = $236.8705 \times 0.28 \text{ g} = 66.323 \text{ g}$ Maximum Donuts = $\frac{180}{66.323} = 2.713... \text{ donuts}$ \therefore Eat a maximum of 2 Scrummy donuts per day.</p>
Specific behaviours
<ul style="list-style-type: none"> ✓ calculates volume correctly using the values of a, b from part (a) ✓ calculates the maximum number of donuts (accept 2.7 donuts)

Question 12

(5 marks)

The vertical displacement, $y(t)$ centimetres, of the seat of a toy horse from the mean position after t seconds is measured as the toy horse moves up and down a pole during a ride on a merry-go-round.

The vertical motion of the toy horse obeys the equation $\frac{d^2y}{dt^2} = -\left(\frac{\pi}{2}\right)^2 y$.

The vertical motion of each toy horse spans 50 centimetres, and the seat of the toy horse is at the mean position at the start of the ride.

(a) Determine the vertical displacement function $y(t)$.

(3 marks)

Solution	
From $\frac{d^2y}{dt^2} = -\left(\frac{\pi}{2}\right)^2 y$ then $y(t) = a \sin(bt)$ where $b = \frac{\pi}{2}$	
Span of motion is 50 cm $\therefore a = 25$. Hence $y(t) = 25 \sin\left(\frac{\pi t}{2}\right)$	
Alternative solutions: $y(t) = 25 \cos\left(\frac{\pi}{2}(t-1)\right)$ OR $y(t) = -25 \sin\left(\frac{\pi t}{2}\right)$	
Specific behaviours	
<ul style="list-style-type: none"> ✓ writes a trigonometric function with $b = \frac{\pi}{2}$ using the correct variables ✓ writes a function that will have an amplitude of 25 cm ✓ writes a trigonometric function that has $y(0) = 0$ 	

(b) Determine the maximum vertical speed of the toy horse, correct to the nearest centimetre per second.

(2 marks)

Solution	
$v(t) = -\frac{25\pi}{2} \cos\left(\frac{\pi t}{2}\right)$ \therefore Maximum speed is given by $\frac{25\pi}{2} = 39.269\dots$ cm/sec	
i.e. Maximum vertical speed is 39 cm/sec.	
Specific behaviours	
<ul style="list-style-type: none"> ✓ forms the correct expression for the velocity function ✓ calculates the maximum speed correctly 	

Question 13

(8 marks)

A brumby is a free-roaming wild horse found in large numbers in parts of Australia. The culling of brumbies was banned in the year 2000. At this time the estimated population of brumbies in Kosciuszko National Park was 1600.

Scientists have modelled the population, $P(t)$, of brumbies in Kosciuszko National Park

t years since the ban, by $P(t) = \frac{18\,000}{10.25e^{-0.15t} + 1}$.

- (a) Use the model to determine how long it will take the brumbies to increase to a number that is triple the number when the ban came into effect. (1 mark)

Solution
Solve when $P(t) = 4800$ i.e. $4800 = \frac{18\,000}{10.25e^{-0.15t} + 1}$
From CAS $t = 8.7711\dots$ years
Specific behaviours
✓ solves for t correctly

- (b) From this model, determine the estimated long run number of brumbies in Kosciuszko National Park. (2 marks)

Solution
Using $t \rightarrow \infty$ then $e^{-0.15t} \rightarrow 0$ hence $P(t) \rightarrow \frac{18\,000}{10.25(0) + 1} = 18\,000$.
Hence in the long term, the limiting population will be 18 000 brumbies.
Specific behaviours
✓ considers $t \rightarrow \infty$ to use $e^{-0.15t} \rightarrow 0$
✓ determines the long run number of brumbies

Question 13 (continued)

It can be shown that the growth rate of the population of brumbies can be expressed as

$$\frac{dP}{dt} = \frac{1}{r}P(k - P).$$

- (c) Determine the values of the constants r and k . (3 marks)

Solution
<p>$k = 18\,000$ as this is the limiting population.</p> <p>$\therefore \frac{dP}{dt} = \frac{1}{r}P(18\,000 - P)$</p> <p>Using $P(t) = \frac{18\,000}{10.25e^{-0.15t} + 1}$ from CAS $P'(0) = 218.666\dots$ (when $P = 1600$)</p> <p>Hence substituting into $\frac{dP}{dt} = \frac{1}{r}P(18\,000 - P)$</p> <p>i.e. $218.666\dots = \frac{1}{r}(1600)(18\,000 - 1600)$</p> <p>$\therefore r = 120\,000$</p>
Specific behaviours
<ul style="list-style-type: none"> ✓ states the value of k correctly ✓ states the value of r correctly ✓ provides justification for the determination of the value for r

- (d) Determine the greatest growth rate for the population of brumbies. (2 marks)

Solution
<p>Greatest rate of growth will occur when $P = 9000$ (half the limiting population)</p> <p>Using $P = 9000$ $\frac{dP}{dt} = \frac{1}{120\,000}(9000)(18\,000 - 9000) = 675$ brumbies per year</p> <p>Hence greatest growth rate will be 675 brumbies per year.</p>
Specific behaviours
<ul style="list-style-type: none"> ✓ states that the maximum growth rate occurs when $P = 0.5k = 9000$ ✓ calculates the maximum growth rate correctly and states the correct units

Alternative Solution
<p>Greatest rate of growth will occur when $\frac{d^2P}{dt^2} = 0$.</p> <p>Solving using CAS gives $t = 15.5151\dots$ yrs</p> <p>Evaluating $P'(15.5151) = 675$</p> <p>Hence greatest growth rate will be 675 brumbies per year.</p>
Specific behaviours
<ul style="list-style-type: none"> ✓ states that the maximum growth rate occurs when $t = 15.51$ ✓ calculates the maximum growth rate correctly and states the correct units

Question 14

(15 marks)

Patients are anaesthetised before surgery. The time, in minutes, it takes for a patient to return to consciousness after surgery, called the ‘recovery time’, is an important measure of the procedure.

Let μ be the population mean recovery time. From historical data, the population standard deviation is $\sigma = 25$ minutes.

A random sample of 100 recovery times is taken of patients who have undergone a tonsillectomy. Let \bar{X} denote the sample mean recovery time.

- (a) State the approximate distribution for \bar{X} . (3 marks)

Solution
<p>Since $n = 100 > 30$ $\bar{X} \sim N\left(\mu, \frac{25^2}{100}\right)$ i.e. approximately normally distributed where $\mu(\bar{X}) = \mu$, $\sigma(\bar{X}) = 2.5$</p>
Specific behaviours
<ul style="list-style-type: none"> ✓ states the distribution is normal ✓ states the mean is μ ✓ states the standard deviation is 2.5

- (b) Determine the probability that the sample mean is greater than the population mean by more than 3 minutes. (2 marks)

Solution
$P(\bar{X} > \mu + 3) = P\left(z > \frac{3}{2.5}\right) = P(z > 1.2) = 0.11506\dots$
Specific behaviours
<ul style="list-style-type: none"> ✓ writes a correct probability statement ✓ calculates the probability correctly

- (c) If it is required that the sample mean is to have a 50% chance of being within m minutes of the population mean, determine the value of m correct to 0.1 minutes. (2 marks)

Solution
<p>We require that $P(\bar{X} - \mu < m) = 0.5$ i.e. $P\left(z < \frac{m}{2.5}\right) = 0.5$ $\therefore \frac{m}{2.5} = 0.6744\dots$ i.e. $m = 1.6862\dots$ Hence $m = 1.7$ minutes</p>
Specific behaviours
<ul style="list-style-type: none"> ✓ writes a correct probability statement using m ✓ calculates the value of m correctly to 0.1 minutes

Question 14 (continued)

A particular sample of size 100 produces $\bar{x} = 15$ minutes.

- (d) Calculate a 99% confidence interval, I_1 , for the population mean recovery time. (2 marks)

Solution
For 99% confidence we require $k = 2.5758...$ $I_1: 15 - 2.5758(2.5) < \mu < 15 + 2.5758(2.5)$ $8.56 < \mu < 21.44$ i.e. $(8.56, 21.44)$
Specific behaviours
<ul style="list-style-type: none"> ✓ uses the correct z score for 99% confidence ✓ calculates the interval limits correctly

A new procedure for tonsillectomy using an assisting robot was trialled. A random sample of 400 recovery times was taken for patients who underwent the new procedure. The observed sample mean was 14.5 minutes.

The 99% confidence interval, I_2 , for the population mean recovery time for the new procedure was found to be $11.28 < \mu(\text{new}) < 17.72$ minutes.

Two junior doctors made the following statements.

Anja: "The new procedure is superior as its sample mean of 14.5 minutes from 400 patients is lower than the sample mean of 15 minutes from 100 patients and by using a larger sample size we can be more confident."

Sanjeet: "Since the interval I_2 lies completely within interval I_1 , then it can be inferred that the population recovery time for the new procedure is the same as that for the old procedure."

- (e) (i) State whether Anja's statement is true or false. Justify your answer. (2 marks)

Solution
Anja's statement is FALSE. This is because we cannot make an inference based on two specific sample means. Sample means will vary between random samples.
Specific behaviours
<ul style="list-style-type: none"> ✓ states that Anja's statement is false ✓ justifies why Anja is not correct

- (ii) State whether Sanjeet's statement is true or false. Justify your answer. (2 marks)

Solution
Sanjeet's statement is FALSE. This is because he cannot compare two confidence intervals that are based on different sample sizes.
Specific behaviours
<ul style="list-style-type: none"> ✓ states that Sanjeet's statement is false ✓ justifies why Sanjeet is not correct

- (f) Calculate the minimum sample size required to estimate the mean recovery time for the new procedure with an interval width of at most 4 minutes using a 95% confidence level. (2 marks)

Solution
Interval half-width is 2 minutes i.e. $2 = (1.96)\left(\frac{25}{\sqrt{n}}\right)$
Solving gives $n = 600.25$ Hence the minimum sample size is 601.
Specific behaviours
✓ forms an equation correctly to solve for n ✓ concludes using the correct integer value for n

Alternative Solution
Solving $n = \left(\frac{1.96 \times 25}{2}\right)^2$ gives $n = 600.25$
Hence the minimum sample size is 601.
Specific behaviours
✓ forms an equation correctly to solve for n ✓ concludes using the correct integer value for n

Question 15

(7 marks)

The graph of $W_k(x) = \left| \frac{k}{2}|x-k| - k \right|$ is called a W-graph where $k > 0$. The graphs of $y = W_2(x)$ and $g(x) = |x-2| - 2$ are shown below for $k = 2$.

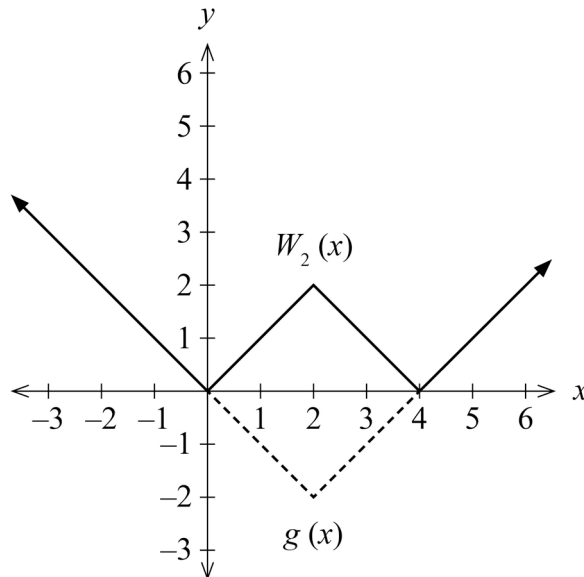

- (a) On the axes below, sketch $y = W_3(x)$ i.e. the W-graph for $k = 3$. (2 marks)

i.e. $W_3(x) = \left| \frac{3}{2}|x-3| - 3 \right|$.

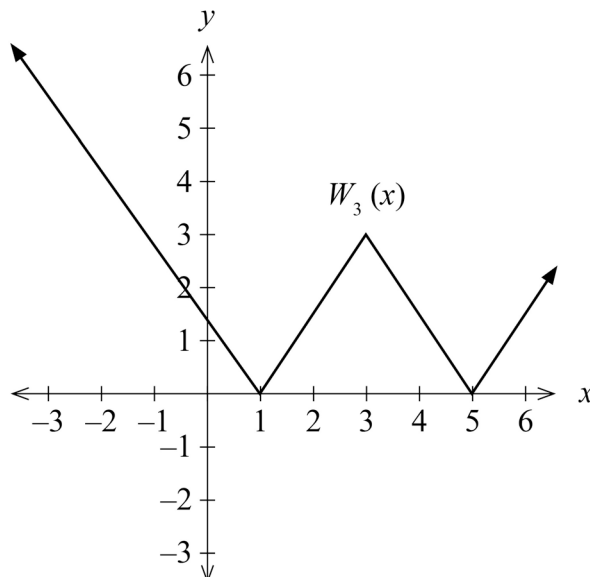

Solution	
Shown above	
Specific behaviours	
✓	indicates the W-graph shape with intercepts $x = 1$ and $x = 5$
✓	indicates symmetry about $x = 3$

(b) Determine how many solutions the equation $W_k(x) = k$ will have. Justify your answer.

(2 marks)

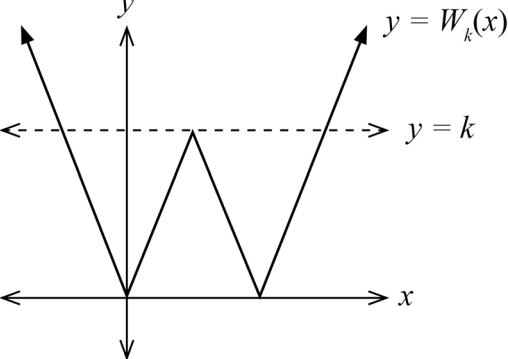
Solution	
<p>A W-graph has a local maximum at $y = k$.</p>  <p>Hence if we consider the graphs of $y = W_k(x)$ and the horizontal line $y = k$, then there will be 3 points of intersection.</p> <p>\therefore There will always be 3 solutions to the equation $W_k(x) = k$.</p>	
Specific behaviours	
<ul style="list-style-type: none">✓ states there will be 3 solutions✓ justifies appropriately by reference to the local maximum at $y = k$	

Question 15 (continued)

- (c) By considering the general W-graph, develop an expression for $\int_{k-2}^{k+2} W_k(x) dx$ in terms of the constant k . (3 marks)

Solution	
<p>In the general case for $y = W_k(x)$, x intercepts occur when $g(x) = \frac{k}{2} x - k - k = 0$ i.e. $x - k = 2$. There are two solutions: $x = k - 2$ and $x = k + 2$.</p>	
$\begin{aligned} \therefore \int_{k-2}^{k+2} W_k(x) dx &= \text{area under } y = W_k(x) \text{ between } x \text{ intercepts} \\ &= \frac{1}{2}((k+2) - (k-2))(k) \\ &= \frac{1}{2}(4)(k) \\ &= 2k \end{aligned}$	
Specific behaviours	
<ul style="list-style-type: none"> ✓ determines the x intercepts for the general case for $y = W_k(x)$ ✓ interprets the definite integral as the area under the graph between the horizontal intercepts of $y = W_k(x)$ ✓ writes the correct expression in terms of k 	

Question 16

(9 marks)

Two thrill-seekers, Karlie and Ben, are each attached to straight wires that allow them to slide down within a wide canyon.

A co-ordinate system is defined showing the positive co-ordinate axes with O being the origin. At exactly 10.30 am, Karlie is at a position of $-200\hat{i} + 300\hat{j} + 700\hat{k}$ metres and is sliding down her wire with velocity $2\hat{i} - \hat{j} - \hat{k}$ metres per second. Meanwhile, Ben is at position $500\hat{i} - 200\hat{j} + 800\hat{k}$ and is sliding down his wire at a velocity of $-0.5\hat{i} + \hat{j} - 1.5\hat{k}$ metres per second.

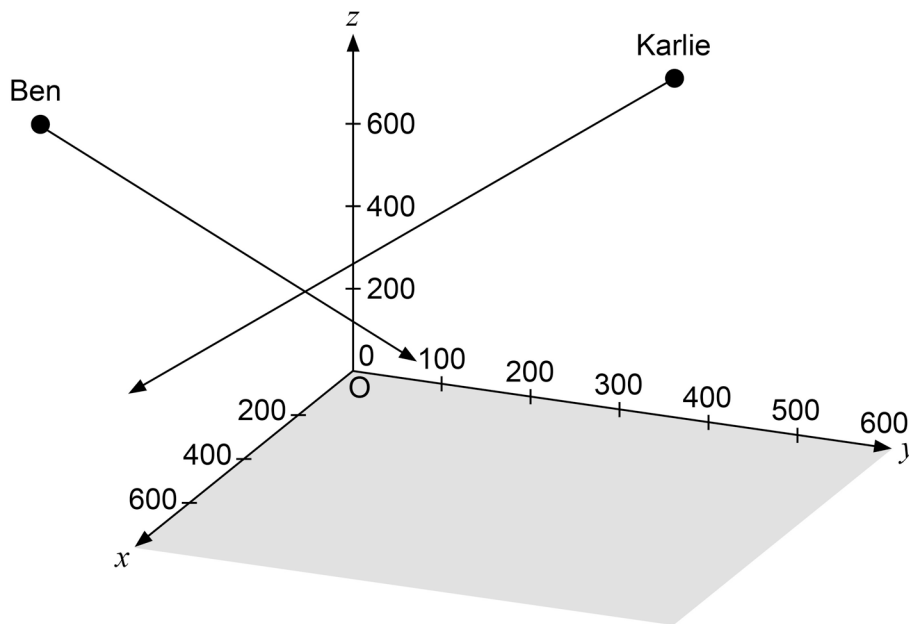

- (a) Determine Ben's speed, correct to the nearest 0.01 metres per second. (2 marks)

Solution	
Ben's speed = $ \underline{v}(\text{Ben}) = \sqrt{(-0.5)^2 + (1)^2 + (-1.5)^2} = 1.8708\dots \text{ m s}^{-1}$ i.e. Ben's speed is 1.87 m s^{-1} (to 0.01 m s^{-1})	
Specific behaviours	
✓	forms the correct expression for the speed
✓	calculates the speed correctly

Question 16 (continued)

- (b) Calculate the angle of Ben’s descent to the horizontal, correct to the nearest degree. (3 marks)

Solution
Normal vector to the horizontal plane is $\underline{n} = 0\underline{i} + 0\underline{j} + 1\underline{k}$
Angle between \underline{n} and $\underline{v}(\text{Ben})$ $\theta = 143.3007\dots^\circ$
Hence angle of descent to the horizontal is $= 90 - \theta = -53.3007\dots^\circ$ i.e. 53°
Specific behaviours
✓ determines the normal vector \underline{n} to the horizontal plane correctly
✓ calculates the angle between the normal vector \underline{n} and $\underline{v}(\text{Ben})$ correctly
✓ calculates the angle to the horizontal correctly to nearest degree

It was found that the closest that Karlie and Ben approached one another was approximately 57.74 metres after 266.67 seconds of motion (from 10.30 am).

Suppose that Ben is able to adjust the speed of his descent and the time at which he commences sliding down his wire.

- (c) Calculate the minimum distance (correct to the nearest 0.01 metres) that Ben could be separated from Karlie, if he was able to adjust the speed and timing of his motion. Show all evidence of your working. (4 marks)

Solution
The question is equivalent to finding the closest approach of one line in space to another. We need to use independent parameters to describe the equation of each line in space.
Equation of the line for Karlie: $\underline{r}(K) = \begin{pmatrix} -200 \\ 300 \\ 700 \end{pmatrix} + \lambda \begin{pmatrix} 2 \\ -1 \\ -1 \end{pmatrix}$
Equation of the line for Ben: $\underline{r}(B) = \begin{pmatrix} 500 \\ -200 \\ 800 \end{pmatrix} + \mu \begin{pmatrix} -0.5 \\ 1 \\ -1.5 \end{pmatrix}$
The separation vector $\overline{KB} = \begin{pmatrix} 500 - 0.5\mu \\ -200 + \mu \\ 800 - 1.5\mu \end{pmatrix} - \begin{pmatrix} -200 + 2\lambda \\ 300 - \lambda \\ 700 - \lambda \end{pmatrix} = \begin{pmatrix} 700 - 0.5\mu - 2\lambda \\ -500 + \mu + \lambda \\ 100 - 1.5\mu + \lambda \end{pmatrix}$
For the minimum separation vector, we need the values of λ, μ such that $\overline{KB} \perp \underline{v}(K)$ and $\overline{KB} \perp \underline{v}(B)$.
We require $\overline{KB} \bullet \underline{v}(K) = 0$ i.e. $\begin{pmatrix} 700 - 0.5\mu - 2\lambda \\ -500 + \mu + \lambda \\ 100 - 1.5\mu + \lambda \end{pmatrix} \bullet \begin{pmatrix} 2 \\ -1 \\ -1 \end{pmatrix} = 0$
i.e. $1800 - 0.5\mu - 6\lambda = 0 \dots (1)$

We require $\overline{KB} \bullet \underline{v}(B) = 0$ i.e.
$$\begin{pmatrix} 700 - 0.5\mu - 2\lambda \\ -500 + \mu + \lambda \\ 100 - 1.5\mu + \lambda \end{pmatrix} \bullet \begin{pmatrix} -0.5 \\ 1 \\ -1.5 \end{pmatrix} = 0$$

i.e. $-1000 + 3.5\mu + 0.5\lambda = 0 \dots (2)$

Solving (1), (2) simultaneously gives $\lambda = 279.518\dots$ and $\mu = 245.783\dots$

Hence the minimum separation vector $\overline{KB} = \begin{pmatrix} 18.072\dots \\ 25.301\dots \\ 10.843\dots \end{pmatrix}$

OR

For the minimum separation vector, we need the values of λ, μ such that $\overline{KB} \perp \underline{v}(K)$ and $\overline{KB} \perp \underline{v}(B)$ i.e. $\overline{KB} \parallel (\underline{v}(B) \times \underline{v}(K))$

$\underline{v}(B) \times \underline{v}(K) = \begin{pmatrix} 2.5 \\ 3.5 \\ 1.5 \end{pmatrix}$ i.e.
$$\begin{pmatrix} 700 - 0.5\mu - 2\lambda \\ -500 + \mu + \lambda \\ 100 - 1.5\mu + \lambda \end{pmatrix} = k \begin{pmatrix} 2.5 \\ 3.5 \\ 1.5 \end{pmatrix}$$

Solving simultaneously for λ, μ, k : $\lambda = 279.518\dots$, $\mu = 245.783\dots$, $k = 7.228\dots$

Hence the minimum separation vector $\overline{KB} = 7.228 \begin{pmatrix} 2.5 \\ 3.5 \\ 1.5 \end{pmatrix} = \begin{pmatrix} 18.072\dots \\ 25.301\dots \\ 10.843\dots \end{pmatrix}$

\therefore Minimum closest approach = $|\overline{KB}| = 32.929\dots$ metres.

Hence if Ben could adjust his speed and timing then the closest he could get to Karlie is 32.93 metres (to 0.01 metres).

Specific behaviours

- ✓ uses independent parameters to determine the equation of each line in space
- ✓ writes the equation for each line in space correctly
- ✓ states the condition for the closest approach in terms of a vector statement
- ✓ calculates correctly the minimum separation distance OR calculates correctly the minimum separation vector

Question 17

(9 marks)

A pressure sensitive device measures depth as it sinks toward the seabed. The device is released from rest at the ocean surface, and as it sinks downward, the water exerts a resistance force to oppose its motion.

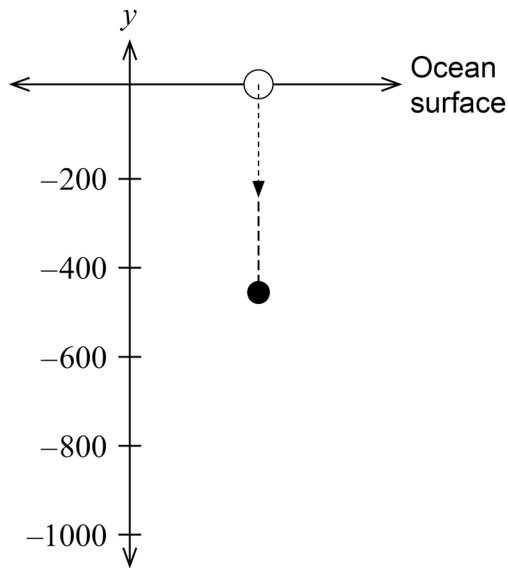

Let t = the time (in seconds) elapsed from release.

$y(t)$ = the displacement of the device relative to the surface (metres).

$v(t)$ = the velocity of the device (metres per second).

$a(t)$ = the acceleration of the device (metres/second²).

The diagram shows that after 95 seconds, the device is 463.05 metres below the surface i.e. $y(95) = -463.05$.

The acceleration of the device, at any point in time, is given by $\frac{dv}{dt} = -9.8 - 2v$.

- (a) Calculate the acceleration of the device, when the device is falling at a rate of 3 metres per second. (2 marks)

Solution	
	Substituting $v = -3$ we obtain $a = -9.8 - 2(-3) = -3.8 \text{ m s}^{-2}$
Specific behaviours	
✓	substitutes $v = -3$ into the differential equation $a = -9.8 - 2v$
✓	calculates the acceleration correctly using correct units

The graph of the acceleration $\frac{dv}{dt}$ is shown below.

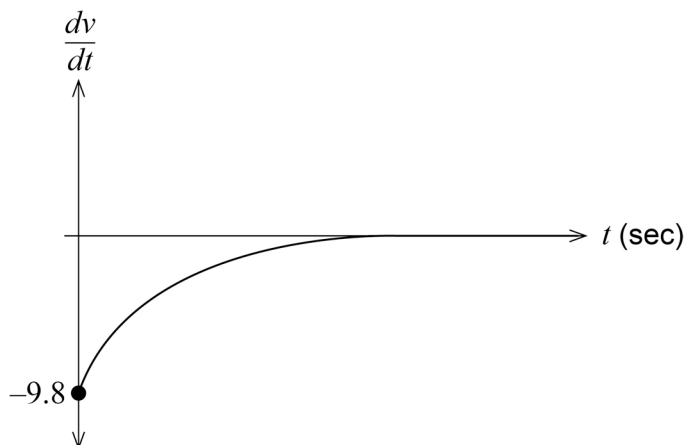

- (b) Explain **two** features of the graph of the acceleration $a(t)$ on page 16, referring to the differential equation $\frac{dv}{dt} = -9.8 - 2v$ or to the resistance force. (2 marks)

Solution
Some features of the graph are:
1. The acceleration is always negative since the rate of change of the velocity is always less than zero.
2. As $t \rightarrow \infty$ the acceleration becomes zero as the resistance to the motion balances the force of gravity. That is, the term $2v \rightarrow -9.8$
3. The magnitude of the acceleration is greatest when $t = 0$ since $v = 0$ when there is no resistance to the motion.
NOTE: Answers must not merely state the features of the graph but must either refer to the differential equation or to the resistance force.
Specific behaviours
✓ explains one feature of the graph
✓ explains a second feature of the graph

- (c) Show, using the separation of variables technique, that $v(t) = 4.9(e^{-2t} - 1)$. (3 marks)

Solution
From $\frac{dv}{dt} = -9.8 - 2v \quad \int \frac{1}{9.8 + 2v} dv = - \int dt$
i.e. $\int \frac{1}{4.9 + v} dv = -2 \int dt \dots\dots (1)$
$\therefore \ln 4.9 + v = -2t + c \dots\dots (2)$
i.e. $4.9 + v = e^{-2t+c} = k.e^{-2t}$
Using $v(0) = 0$ then $4.9 + 0 = k(e^0) \therefore k = 4.9$
Hence, $4.9 + v = 4.9e^{-2t}$
i.e. $v(t) = 4.9e^{-2t} - 4.9 = 4.9(e^{-2t} - 1)$ as required.
Specific behaviours
✓ separates variables to form statement (1) or its equivalent
✓ integrates correctly to form statement (2) or its equivalent
✓ uses $v(0) = 0$ correctly to deduce the integration constant

Question 17 (continued)

At a particular location, the device is released from rest at the surface of the ocean and falls until it strikes the seabed.

- (d) If the device takes exactly 2 minutes 30 seconds to hit the seabed, calculate the depth of the seabed at this location, correct to the nearest metre. (2 marks)

Solution
2 minutes 30 seconds = 150 seconds of motion Require $\Delta y = \int_0^{150} v(t) dt = -732.55$ i.e. the depth of the ocean is 733 metres (nearest metre)
Specific behaviours
<ul style="list-style-type: none"> ✓ writes a definite integral using $v(t)$ and uses the correct limits ✓ calculates the depth correct to the nearest metre

Alternative Solution
2 minutes 30 seconds = 150 seconds of motion $y(t) = \int v(t) dt = \int 4.9(e^{-2t} - 1) dt$ i.e. $y(t) = 4.9\left(\frac{e^{-2t}}{-2} - t\right) + c$ Using $y(0) = 0$ or $y(95) = -463.05$ obtains $c = 2.45$ i.e. $y(t) = -2.45e^{-2t} - 4.9t + 2.45$ Require $y(150) = -732.55$ i.e. the ocean depth is 733 metres (nearest metre)
Specific behaviours
<ul style="list-style-type: none"> ✓ anti-differentiates correctly to determine $y(t)$ ✓ calculates the depth correct to the nearest metre

Question 18

(12 marks)

A drone's position vector is given by $\underline{r}(t) = \begin{pmatrix} e^t + e^{-t} \\ e^t - e^{-t} \end{pmatrix}$ metres where t is measured in seconds for $0 \leq t \leq 5$. A plot of the path of the drone is shown below.

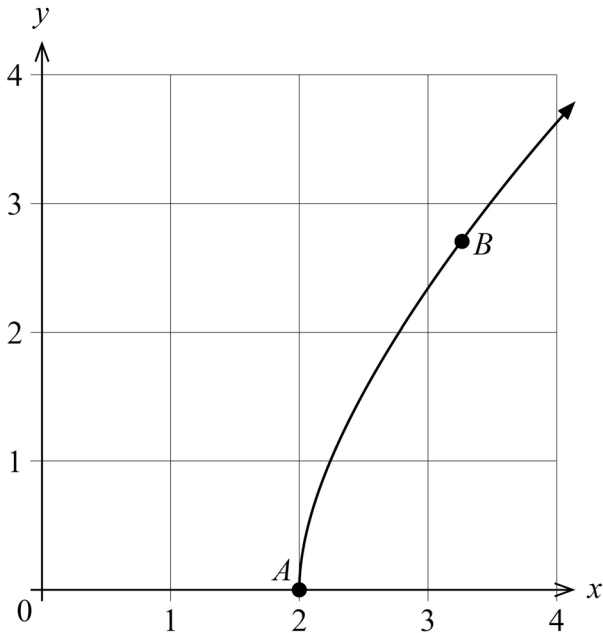

The drone starts its motion at point A and is at point B when $t = \ln 3$.

- (a) Determine the position vector for point B exactly. (2 marks)

Solution	
When $t = \ln 3$	$x = e^{\ln 3} + e^{-\ln 3} = 3 + \frac{1}{3} = \frac{10}{3}$
$y = e^{\ln 3} - e^{-\ln 3} = 3 - \frac{1}{3} = \frac{8}{3}$	$\therefore \underline{r}(\ln 3) = \begin{pmatrix} \frac{10}{3} \\ \frac{8}{3} \end{pmatrix} = \begin{pmatrix} 3.\dot{3} \\ 2.\dot{6} \end{pmatrix}$
Specific behaviours	
✓ indicates that $e^{\ln 3} = 3$	
✓ determines the correct position vector for B	

- (b) Determine the velocity vector $\underline{v}(t)$. (2 marks)

Solution	
$\underline{v}(t) = \underline{r}'(t) = \begin{pmatrix} e^t - e^{-t} \\ e^t + e^{-t} \end{pmatrix}$	
Specific behaviours	
✓ recognises that the velocity vector is the derivative of displacement vector	
✓ determines the correct components for the velocity vector	

Question 18 (continued)

- (c) Calculate the distance travelled from point A to point B , correct to 0.001 metres. (3 marks)

Solution	
Distance travelled =	$\int_0^{\ln 3} v(t) dt = \int_0^{\ln 3} \sqrt{(e^t - e^{-t})^2 + (e^t + e^{-t})^2} dt$ $= \int_0^{\ln 3} \sqrt{2e^{2t} + 2e^{-2t}} dt$ $= 3.036 \text{ m (to 0.001 metres)}$
Specific behaviours	
<ul style="list-style-type: none"> ✓ forms a definite integral using the correct limits for t ✓ uses the correct expression for the speed function ✓ evaluates the definite integral correctly to 0.001 m 	

- (d) After 2 seconds of motion, calculate correct to 0.1 degrees, the direction in which the drone is travelling. (2 marks)

Solution	
$v(2) =$	$\begin{pmatrix} e^2 - e^{-2} \\ e^2 + e^{-2} \end{pmatrix} = \begin{pmatrix} 7.253... \\ 7.524... \end{pmatrix}$
Direction is given by	$\tan \theta = \frac{7.524..}{7.253..} = 1.037... \quad \therefore \theta = 46.049..^\circ$
\therefore Drone is moving in a direction of 46.0° (to 0.1 degrees) to the positive x axis.	
Specific behaviours	
<ul style="list-style-type: none"> ✓ determines the velocity vector $v'(2)$ correctly ✓ determines the direction of motion correctly 	

- (e) Determine the Cartesian equation for the path of the drone. (3 marks)

Solution	
$r(t) =$	$\begin{pmatrix} x \\ y \end{pmatrix} = \begin{pmatrix} e^t + e^{-t} \\ e^t - e^{-t} \end{pmatrix} \quad \text{i.e. } \begin{matrix} x = e^t + e^{-t} \\ y = e^t - e^{-t} \end{matrix}$
Hence	$\begin{matrix} x + y = 2e^t \\ x - y = 2e^{-t} \end{matrix}$
\therefore	$(x + y)(x - y) = 2e^t \cdot 2e^{-t} = 4e^0 = 4$
\therefore	Cartesian equation is $x^2 - y^2 = 4$ where $y \geq 0$ and $x \geq 2$ OR $y = \sqrt{x^2 - 4}$ (this gives $y \geq 0$ values but $x \geq 2$)
Note: the domain $2 \leq x \leq e^5 + e^{-5}$ is not required.	
Specific behaviours	
<ul style="list-style-type: none"> ✓ obtains an expression for $x + y$ or $x - y$ in terms of t ✓ eliminates the parameter t correctly to deduce $x^2 - y^2 = 4$ or its equivalent ✓ restricts the values for x and y to obtain the actual path of the drone 	

Alternative Solution
$\underline{r}(t) = \begin{pmatrix} x \\ y \end{pmatrix} = \begin{pmatrix} e^t + e^{-t} \\ e^t - e^{-t} \end{pmatrix} \quad \text{i.e. } \begin{aligned} x &= e^t + e^{-t} \\ y &= e^t - e^{-t} \end{aligned}$ <p>Hence $x^2 = (e^t + e^{-t})^2 = e^{2t} + 2 + e^{-2t}$</p> $y^2 = (e^t - e^{-t})^2 = e^{2t} - 2 + e^{-2t}$ $\therefore x^2 - y^2 = (e^{2t} + 2 + e^{-2t}) - (e^{2t} - 2 + e^{-2t}) = 4$ <p>\therefore Cartesian equation is $x^2 - y^2 = 4$ where $y \geq 0$ and $x \geq 2$</p> <p>OR $y = \sqrt{x^2 - 4}$ (this gives $y \geq 0$ values but $x \geq 2$)</p> <p>Note: the domain $2 \leq x \leq e^5 + e^{-5}$</p>
Specific behaviours
<ul style="list-style-type: none"> ✓ obtains an expression for x^2 or y^2 in terms of t ✓ eliminates the parameter t correctly to deduce $x^2 - y^2 = 4$ or its equivalent ✓ restricts the values for x and y to obtain the actual path of the drone

Copyright

© School Curriculum and Standards Authority, 2024

This document – apart from any third-party copyright material contained in it – may be freely copied, or communicated on an intranet, for non-commercial purposes in educational institutions, provided that it is not changed and that the School Curriculum and Standards Authority (the Authority) is acknowledged as the copyright owner, and that the Authority's moral rights are not infringed.

Copying or communication for any other purpose can be done only within the terms of the *Copyright Act 1968* or with prior written permission of the Authority. Copying or communication of any third-party copyright material can be done only within the terms of the *Copyright Act 1968* or with permission of the copyright owners.

Any content in this document that has been derived from the Australian Curriculum may be used under the terms of the Creative Commons [Attribution 4.0 International \(CC BY\)](https://creativecommons.org/licenses/by/4.0/) licence.

*Published by the School Curriculum and Standards Authority of Western Australia
303 Sevenoaks Street
CANNINGTON WA 6107*