



## ATAR course examination, 2018

# PHYSICAL EDUCATION STUDIES

## Practical (performance) examination Cricket

### Time allowed

Warm up: 30 minutes  
Skills and drills: 75 minutes

### Materials required

#### *To be provided at the venue*

Non-personal equipment required for Cricket

#### *To be provided by the candidate*

Cricket bat, batting helmet, gloves, pads, protector and enclosed shoes or boots for a hard wicket

## Structure of the examination

The Physical Education Studies ATAR course examination consists of a written component and a practical (performance) component.

## Criteria for marking the practical (performance) examination

Criteria	Marks available	Percentage of practical examination
Skills performance	30	50
Conditioned performance	20	50
<b>Total</b>		100

## Instructions to candidates

1. You are required to wear clothing and personal playing and safety equipment that is approved for competition by the sport's governing body.
2. Clothing must not identify you, your school, club or achievements, and it is requested that you wear black, navy or a white shirt for the examination.
3. You are required to report to a supervisor to register for the practical examination 40 minutes before your scheduled examination time.
4. Once your attendance has been recorded you will be given a coloured, numbered bib to wear for the examination and you will be directed to a supervised warm up area.
5. Just prior to the scheduled examination time you will be escorted from the warm up area to the examination area.
6. You must follow the requirements for this examination published in the *Physical Education Studies ATAR course Practical (performance) examination requirements 2018* document.

## SECTION ONE – Skills Performance

## 1. Skills set

(30 marks)

Skill 1	Skill 2	Skill 3	Skill 4	Skill 5
Outfield catch	Infield: Ground fielding and overarm throw	Front foot stroke production	Back foot offensive stroke production	Bowling: Pace (swing and seam) or spin

**Drill #1:** Outfield catch

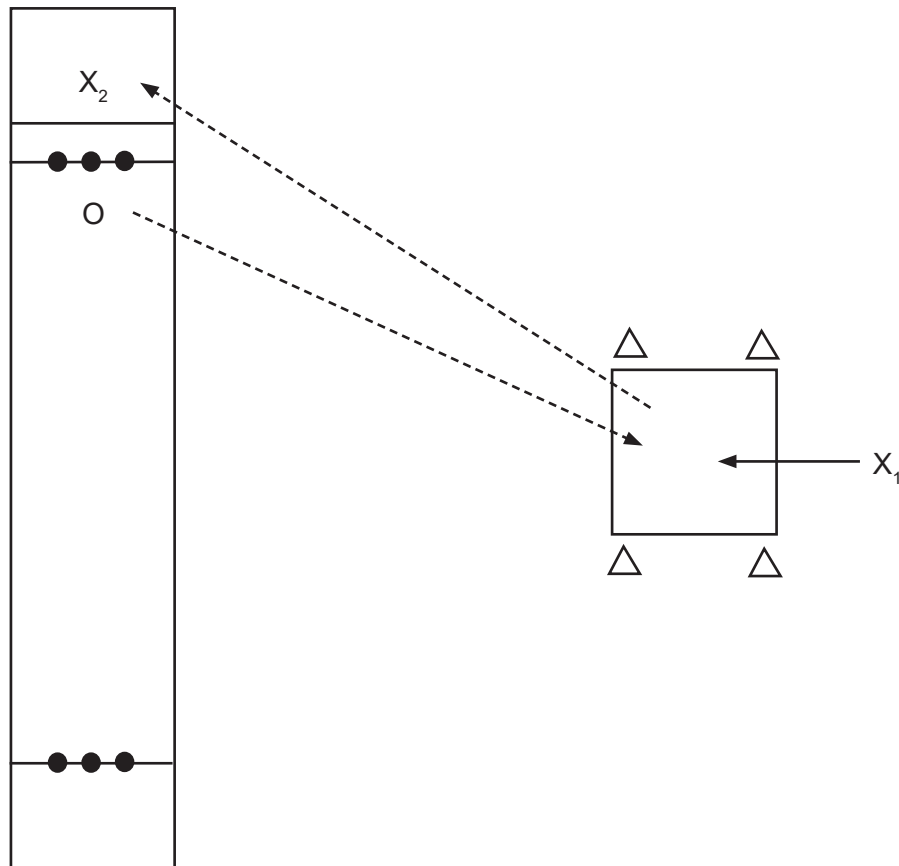

**Key:**

X	= player
O	= feeder
△	= marker
————→	= player movement
- - - - ->	= ball movement

**Drill description**

1. Feeder strikes a high ball to land in a 20 m square, which is 50 m from the batting crease.
2. Player  $X_1$  starts 10 m from the furthest side of the square and must move and catch the ball after it has been struck.
3. The ball is to be caught inside the 20 m square.
4. Player  $X_1$  throws ball to the wicketkeeper ( $X_2$ ).

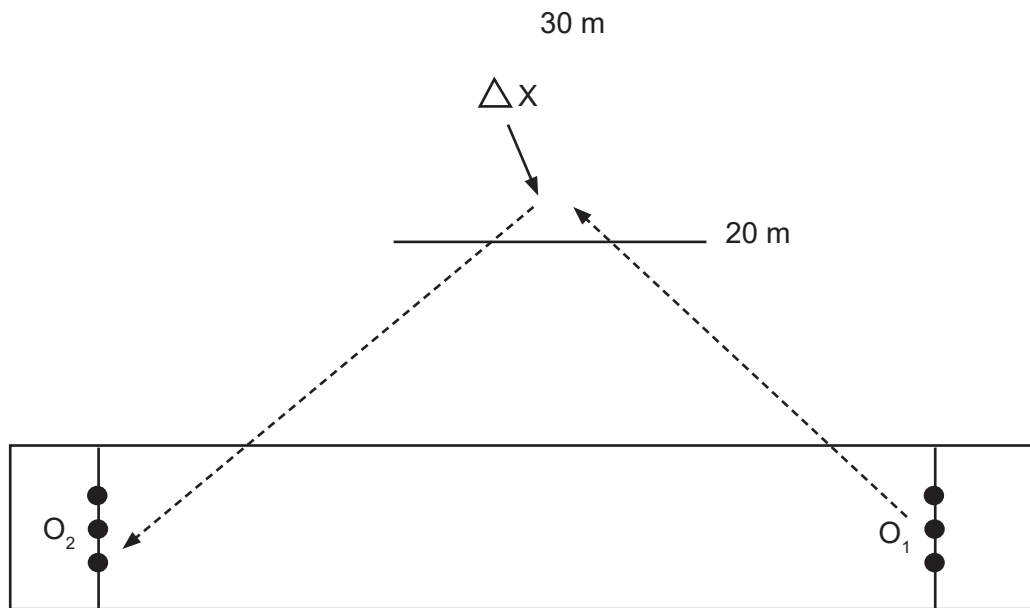
**Drill #2:** Infield: ground fielding and overarm throw

**Key:**

X	= player
O	= feeder
△	= marker
————→	= player movement
- - - - ->	= ball movement

**Drill description**

1. Stumps set up with a marker 30 m from the stumps at a position mid-pitch (cover or midwicket fielding positions).
2. Line marked 20 m from the stumps at the striker's end.
3. Ball is struck firmly along the ground towards the player X by the feeder ( $O_1$ ) from the striker's end.
4. Player X fields the ball and throws overarm at the stumps at the non-striker's end.
5. Feeder  $O_2$  is standing over the stumps.

**Drill #3:** Front foot stroke production, Back foot offensive stroke production

Front foot stroke production

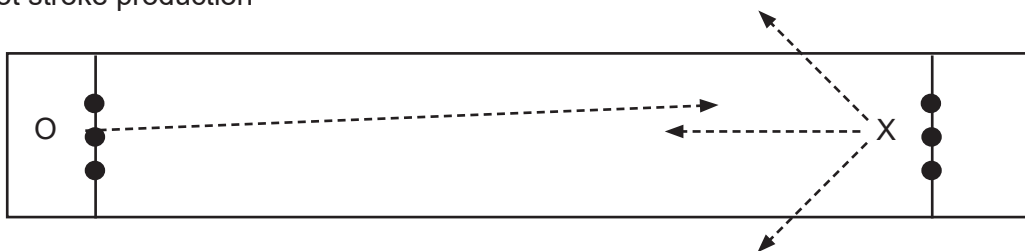

Back foot offensive stroke production

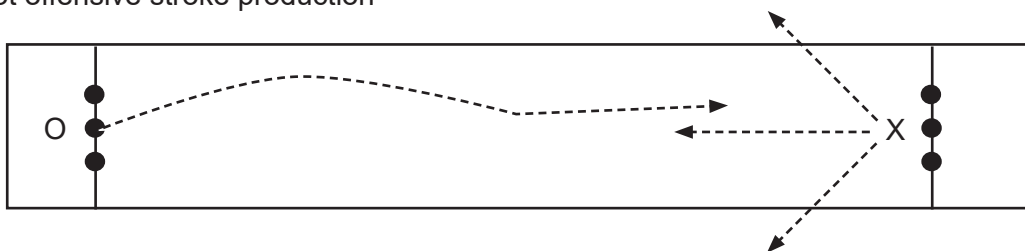

- Key:**
- X = player
  - O = feeder
  - △ = marker
  - = player movement
  - - - → = ball movement

**Drill description**

1. Feeder to deliver a range of full length and short pitched balls to the player X.
2. Full length balls are straight, on line with the off stump and bounce 3 m – 4 m from the stumps. Player X is to execute a front foot stroke from this delivery.
3. Short pitched balls are straight, on line or just outside the off stump and landing 8 m – 10 m from the stumps. Player X is to execute a back foot offensive stroke from this delivery.

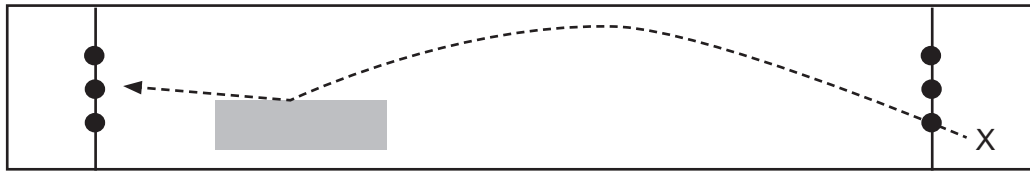
**Drill #4:** Bowling: Pace (swing and seam) or spin

**Key:**

X	= player
O	= feeder
△	= marker
→	= player movement
- - - - ->	= ball movement
■	= target area

**Drill description**

1. Player X selects to bowl either pace (swing or seam) or spin.
2. Each player delivers the ball while aiming to swing, seam or spin the ball, land the ball in the target zone and directed at the off stump.
3. The target zone is 2 m long and 80 cm wide in line with the right-hander's middle stump (extending 40 cm either side of the middle stump), starting 3 m from the stump.

SECTION TWO – Conditioned Performance

(20 marks)

SCENARIO PLANNING	
DEFINE PLAYING AREA OR BOUNDARIES	Cricket pitch
SPECIFY NUMBER OF PLAYERS	8
SPECIFY TACTICAL PROBLEM(S) TO BE SOLVED	<p>Game scenario: The end of a T20 or limited overs match where the batters are trying to score 20 runs from 12 balls.</p> <p>Two batters face a total of two overs (12 balls) rotating where required so that each is given the opportunity to face 6 balls. The batters should show positive intent (scoring shots, rotating strike, running between wickets) to demonstrate urgency for scoring runs. The batter is expected to play a variety of shots.</p> <p>The batters' objective is to score 20 runs from 12 balls.</p> <p>Two bowlers are required to bowl one over (6 balls) each with a total of 12 balls to the two batters. They need to communicate with the markers to indicate what they are trying to do (where and the type of delivery). The bowlers also need to set an appropriate field using other candidates and helpers. The bowlers can adjust their field placements each ball.</p> <p>The bowler's objective is to take wickets, contain batter and/or restrict runs from being scored.</p>
SPECIFY ROLES OR GOALS OF PLAYER(S)	<p>Placement of ball to allow runs and attempted outs by fielders and bowler.</p> <p>The next two batters are off the field padding up.</p>
SPECIFY OPTIONS, RULES &/OR RESTRICTIONS	Normal rules apply.



**This page has been left blank intentionally**

**This page has been left blank intentionally**

**This page has been left blank intentionally**

This document – apart from any third party copyright material contained in it – may be freely copied, or communicated on an intranet, for non-commercial purposes in educational institutions, provided that it is not changed and that the School Curriculum and Standards Authority is acknowledged as the copyright owner, and that the Authority’s moral rights are not infringed.

Copying or communication for any other purpose can be done only within the terms of the *Copyright Act 1968* or with prior written permission of the School Curriculum and Standards Authority. Copying or communication of any third party copyright material can be done only within the terms of the *Copyright Act 1968* or with permission of the copyright owners.

Any content in this document that has been derived from the Australian Curriculum may be used under the terms of the Creative Commons [Attribution 4.0 International \(CC BY\)](https://creativecommons.org/licenses/by/4.0/) licence.

*Published by the School Curriculum and Standards Authority of Western Australia  
303 Sevenoaks Street  
CANNINGTON WA 6107*