



Government of **Western Australia**
School Curriculum and Standards Authority



ENGINEERING STUDIES
ATAR COURSE

DATA BOOK

2024

CONTENT	PAGES
<hr/>	
Core content	
Base International System (SI) units	
Selected derived SI units	
Other units	
SI prefixes	
Common constant	3–5
General formulae	
Right triangular plane figures	
Circles, cylinder and sphere figures	
Density, energy and efficiency	
Materials properties	
<hr/>	
Specialist field mechanical	
Materials formulae	
Statics formulae	
Selected derived SI units	6–9
Common constant	
Statics – second moment of area for material cross sections	
Statics – deflection of beams	
Dynamics formulae	
<hr/>	
Specialist field mechatronics	
Base International System (SI) units	
Selected derived SI units	
Law and principle formulae	
Mechanics formulae	10–15
Standard circuit symbols	
Resistor colour codes	
Diode and transistor	
Standard microcontroller chip	
Flow chart symbols	
<hr/>	

Base International System (SI) units

Quantities	SI units	
	Names	Symbols
Length	metre	m
Mass	kilogram	kg
Time	second	s

Selected derived SI units

Derived quantities	Names	Symbols
Energy, work, quantity of heat	joule	J
Power	watt	W
Area	square metre	m ²
Volume (gas)	cubic metre	m ³
Speed, velocity	metre per second	m s ⁻¹
Mass density	kilogram per cubic metre	kg m ⁻³

Other units

Derived quantities	Names	Symbols
Temperature (Celsius)	degrees Celsius	°C
Volume (liquid)	litre	L

SI prefixes

Prefixes	Abbreviations	Multipliers
Tera	T	10 ¹² = 1 000 000 000 000
Giga	G	10 ⁹ = 1 000 000 000
Mega	M	10 ⁶ = 1000 000
Kilo	k	10 ³ = 1000
		10 ⁰ = 1
Milli	m	10 ⁻³ = 0.001
Micro	μ	10 ⁻⁶ = 0.000 001
Nano	n	10 ⁻⁹ = 0.000 000 001
Pico	p	10 ⁻¹² = 0.000 000 000 001

Common constant

Item	Symbol	Value
Pi	π	3.14159

General formulae

Right triangular plane figures	Formulae
Pythagoras (side lengths)	$h^2 = o^2 + a^2$
Angular relationships	$\cos \theta = \frac{a}{h}$ $\sin \theta = \frac{o}{h}$ $\tan \theta = \frac{o}{a}$
Circles, cylinder and sphere figures	Formulae
Circumference [C] of a circle	$C = \pi d$
Area [A] of a circle	$A = \pi r^2$
Surface area [A] of open-ended cylinder	$A = \pi dh$
Surface area [A] of a sphere	$A = 4\pi r^2$
Volume [V] of a cylinder	$V = \pi r^2 h$
Volume [V] of a sphere	$V = \frac{4}{3} \pi r^3$
Density, energy and efficiency	Formulae
Density [ρ]	$\rho = \frac{m}{V}$
Energy [E]	$E = Pt$
Efficiency [η] %	$\eta\% = \frac{\text{output}}{\text{input}} \times 100$

Materials properties (at room temperature)

Materials	Density kg m ⁻³	Elastic (Young's) modulus kN mm ⁻²	Ultimate tensile * strength N mm ⁻²	Yield stress N mm ⁻²	Electrical conductivity Ω ⁻¹ m ⁻¹ × 10 ⁶	Thermal conductivity W m ⁻¹ K ⁻¹
Structural steel	7850	200	470	250	13.00	46
Stainless steel	7600	200	860	502	1.35	16
Cast iron	7200	120	180		10.30	80
Wrought iron	7750	200			10.30	80
Aluminium	2710	70	150	95	37.70	237
Brass	8740	90	190	50	16.70	109
Copper	8930	112	210	70	59.50	401
Zinc	7130	108	200	13.80	16.80	116
Solder	9280	23.7	37	–	7.28	43.60
Concrete	2400	30	40 (compressive)			0.80
Timber (parallel to grain)		12	105			0.16
Polypropylene	1240	4	19.7 – 80	50		0.13
Polycarbonate	1200	2.30	70			0.19
ABS plastics		2.30	40	48.30		2.34
Nylon	1160	2 – 4	75	45		
Acrylic	1190	3.20	70	73.70		0.19
Glass	2500	69		3600		1.05
Diamond	3520	1000		50 000		2320
Gold	19 320	82	220	40	44.60	318
Ice	931	9.17(@-5°C)		85		2.25(@-5°C)
Pure water	1000					
Sea water	1022					
Petrol	740					0.15
Crude oil	800					0.15

* Unless noted as compressive strength.

Materials formulae

Parameters	Formulae
Stress [σ]	$\sigma = \frac{F}{A}$
Strain [ε]	$\varepsilon = \frac{\Delta L}{L}$
Young's modulus [E] (elastic modulus)	$E = \frac{\sigma}{\varepsilon}$
Young's modulus [E] expanded formula	$E = \frac{FL}{A\Delta L}$
Factor of Safety [FS]	$FS = \frac{\sigma_{UTS}}{\sigma_{safeworking}}$

Statics formulae

Parameters	Formulae
Moment [M] of a force	$M = Fd$
Equilibrium conditions	$\Sigma M = 0$ $\Sigma F_y = 0$ $\Sigma F_x = 0$
Equilibrium conditions (expanded)	$\Sigma CW M = \Sigma ACWM$ $\Sigma F(up) = \Sigma F(down)$ $\Sigma F(left) = \Sigma F(right)$

Selected derived SI units

Derived quantities	Derived SI units		
	Names	Symbols	Expression in terms of derived SI units
Force	newton	N	–
Pressure, stress	pascal	Pa	$N\ m^{-2}$
Energy, work	joule	J	$N\ m$

Common constant

Item	Symbol	Value
Gravity	g	$9.80\ m\ s^{-2}$

Statics – second moment of area for material cross sections

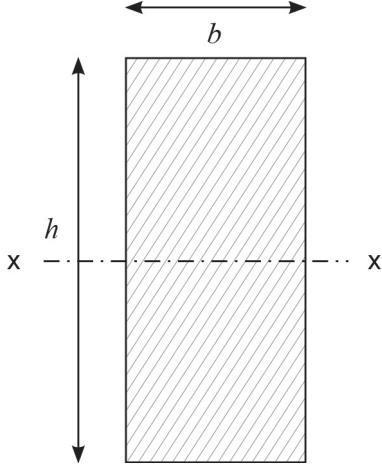
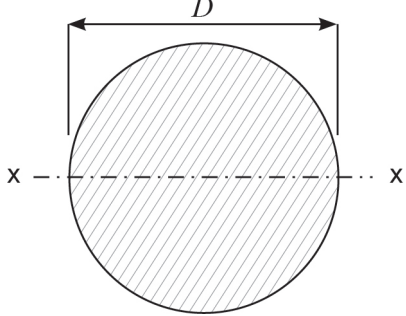
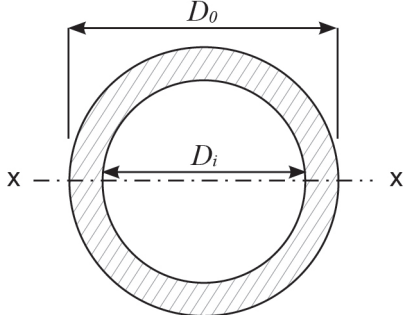
Shapes	Dimensions	Second moment of area about centroidal axis
Vertical rectangle solid section		$I_{xx} = \frac{bh^3}{12}$
Round solid section		$I_{xx} = \frac{\pi D^4}{64}$
Circular tube section		$I_{xx} = \frac{\pi(D_o^4 - D_i^4)}{64}$
<p>Terms: <i>b</i> = base <i>D</i> = diameter <i>D_i</i> = diameter (inside) <i>D_o</i> = diameter (outside) <i>h</i> = height <i>I_{xx}</i> = second moment of area for material cross sections</p>		

Statics – deflection of beams

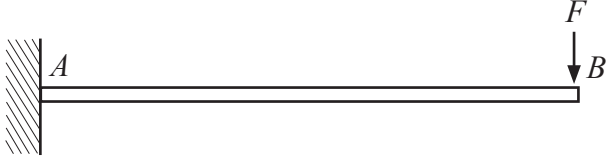
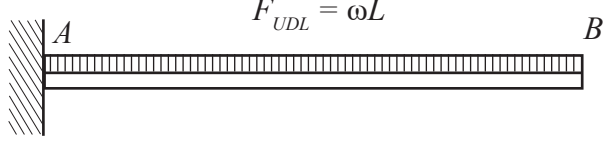
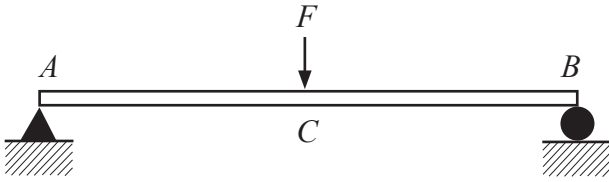
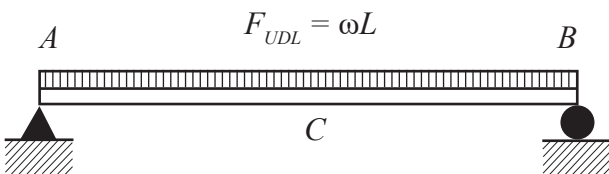
Beam configurations	Maximum bending moment (BM_{max})	Maximum deflection (y)
<p>Cantilevered beam – single load at unsupported end</p> 	$BM_{max} = FL$ at A	$y = \frac{FL^3}{3EI_{xx}}$ at B
<p>Cantilevered beam – universally distributed load</p> 	$BM_{max} = \frac{F_{UDL}L}{2}$ at A	$y = \frac{F_{UDL}L^3}{8EI_{xx}}$ at B
<p>Centrally loaded beam – simply supported at both ends</p> 	$BM_{max} = \frac{FL}{4}$ at C	$y = \frac{FL^3}{48EI_{xx}}$ at C
<p>Universally loaded beam – simply supported at both ends</p> 	$BM_{max} = \frac{F_{UDL}L}{8}$ at C	$y = \frac{5F_{UDL}L^3}{384EI_{xx}}$ at C
<p>Terms:</p> <p>E = elastic (Young's) modulus of the material of the beam</p> <p>F = single vertical point load</p> <p>F_{UDL} = product of the UDL's applied load/unit length and the length of the beam</p> <p>I_{xx} = second moment of area of the beam section</p> <p>L = length of beam between supports</p> <p>ω = uniformly distributed load per unit length</p>		

Dynamics formulae

Parameters	Formulae
Force [F]	$F = ma$
Acceleration [a]	$a = \frac{v - u}{t}$
Velocity [v]	$v^2 = u^2 + 2as$
Distance [s]	$s = ut + \frac{1}{2}at^2$
Work [W]	$W = Fs$
Power [P]	$P = \frac{Fs}{t} = F\bar{v}$
Potential energy [E_p]	$E_p = mgh$
Kinetic energy [E_k]	$E_k = \frac{1}{2}mv^2$
Energy conversion	$\Delta E_p = \Delta E_k$

Base International System (SI) units

Unit name	Unit abbreviation	Electrical parameter	Symbol	Expression in terms of derived SI units
ampere	A	Current	I	$W V^{-1}$

Selected derived SI units

Unit names	Unit abbreviations	Electrical parameters	Symbols	Expression in terms of derived SI units
volt	V	Voltage	V	$W A^{-1}$
ohm	Ω	Resistance	R	$V A^{-1}$
farad	F	Capacitance	C	$A s V^{-1}$
watt	W	Power	P	$J s^{-1}$
hertz	Hz	Frequency	f	s^{-1}

Law and principle formulae

Parameters	Formulae
Relationships between Ohm's law and power formula Power [P] Resistance [R] Voltage [V] Current [I]	$P = VI = I^2R = \frac{V^2}{R}$ $R = \frac{V}{I} = \frac{P}{I^2} = \frac{V^2}{P}$ $V = IR = \frac{P}{I} = \sqrt{PR}$ $I = \frac{V}{R} = \frac{P}{V} = \sqrt{\frac{P}{R}}$
Electrical energy [E_e]	$E_e = VIt$
Kirchhoff's first law	$\Sigma I = 0$
Kirchhoff's second law	$\Sigma \Delta V = 0$
Resistance [R] in series	$R_T = R_1 + R_2 + \dots$
Resistance [R] in parallel	$\frac{1}{R_T} = \frac{1}{R_1} + \frac{1}{R_2} + \dots$
Voltage dividers	$V_{cc} = V_1 + V_2$ $V_1 = V_{cc} \frac{R_1}{R_1 + R_2}$ $V_2 = V_{cc} \frac{R_2}{R_1 + R_2}$
Resistor [R] in series with an LED	$R = \frac{V_{cc} - V_{LED}}{I_{LED}}$
Capacitance [C] in series	$\frac{1}{C} = \frac{1}{C_1} + \frac{1}{C_2} + \dots$
Capacitance [C] in parallel	$C = C_1 + C_2 + \dots$

Mechanics formulae

Parameters	Formulae
Mechanical Advantage [<i>MA</i>]	$MA = \frac{\text{load}}{\text{effort}}$
Velocity Ratio [<i>VR</i>]	$VR = \frac{d_{\text{effort}}}{d_{\text{load}}}$
Pulley belt ratio	$VR = \frac{\text{Ø follower pulley}}{\text{Ø driver pulley}}$
Chain and sprocket ratio	$VR = \frac{n^{\circ} \text{ teeth follower gear}}{n^{\circ} \text{ teeth driver gear}}$
Gear ratio	$VR = \frac{n^{\circ} \text{ teeth follower gear}}{n^{\circ} \text{ teeth driver gear}}$
Velocity ratios [<i>VR</i>] for gear/pulley trains comprised of 3 or more gears/pulleys	$VR = \frac{F_1}{D_1} \frac{F_2}{D_2} \frac{F_3}{D_3} \dots$
Worm and worm wheel ratio	$VR = \frac{n^{\circ} \text{ teeth worm wheel}}{1}$
Rack and pinion	$\text{distance} = \frac{n^{\circ} \text{ teeth pinion} \times \text{revolutions}}{n^{\circ} \text{ teeth per metre rack}}$
Linear velocity [<i>v</i>] of belt or cable driven by pulley or drum	$v = \frac{(\text{RPM}) (2\pi r)}{60} = \frac{s}{t}$
Speed of rotation (rpm)	$\text{Output speed (rpm)} = \frac{\text{Input speed (rpm)}}{VR}$

Standard circuit symbols

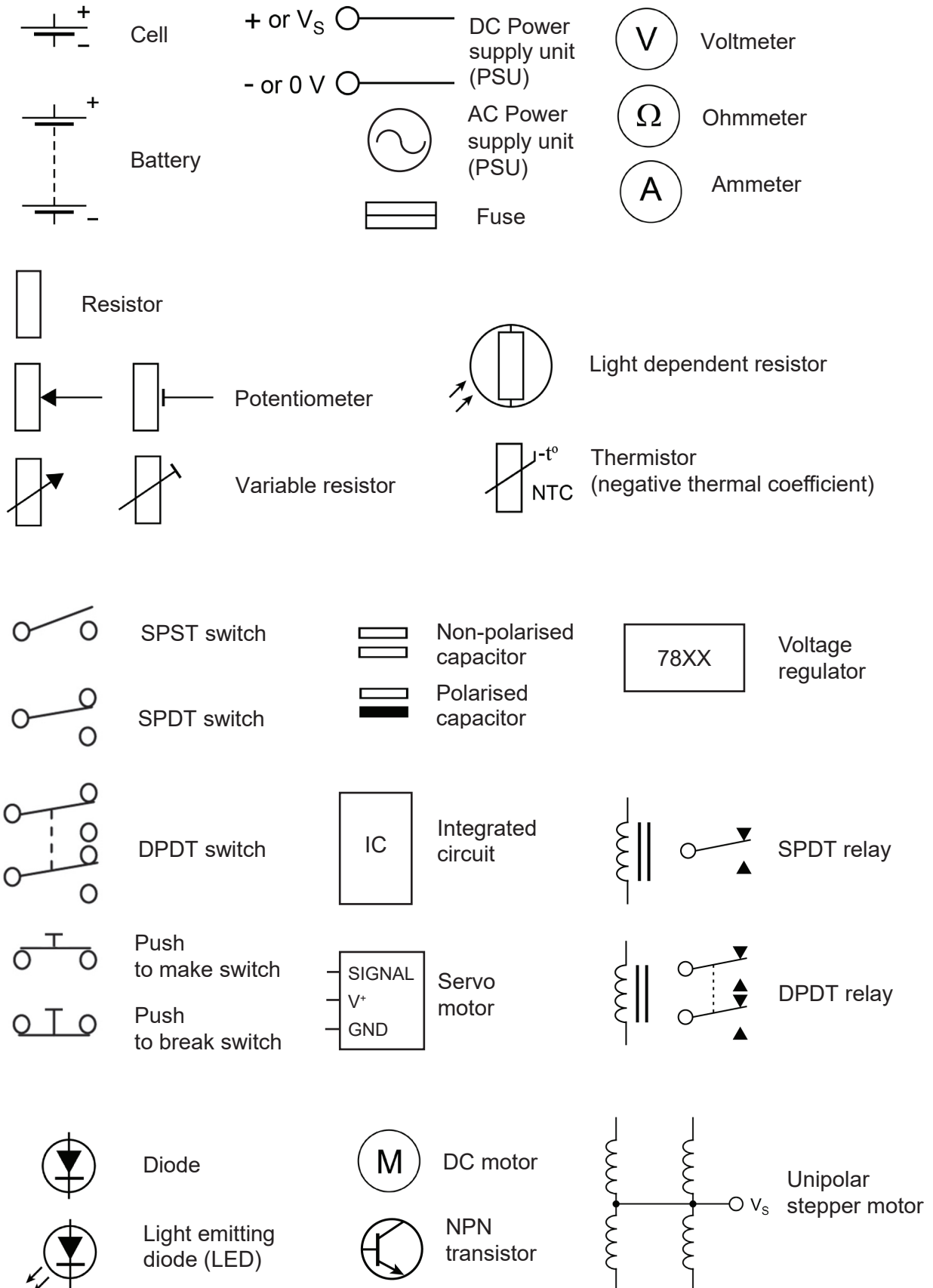

Resistor colour codes

1 0 000 $\pm 5\%$

Example: 4 band E12 series resistor colour code

Band colours	1st band	2nd band	Multiplier	Tolerance band
Black	0	0	1	
Brown	1	1	10	1%
Red	2	2	100	2%
Orange	3	3	1000	
Yellow	4	4	10 000	
Green	5	5	100 000	
Blue	6	6	1 000 000	
Violet	7	7		
Grey	8	8		
White	9	9		
Gold				5%

E12 Preferred values: 10, 12, 15, 18, 22, 27, 33, 39, 47, 56, 68, 82

Diode and transistor

Diode model	Formulae	Diagram
On	$V_D = V_{D,on} \text{ (or } V_F)$ Check: $I_D > 0$	
Off	$I_D = 0 A$ Check: $V_D < V_{D,on} \text{ (or } V_F)$	
Transistor model (NPN BJT)	Formulae	Diagram
Cut-off	$I_B = I_C = 0 A$ Check: $V_{BE} < 0.7 V$	
Saturation	$V_{BE} = 0.7 V$ $V_{CE} = 0 V$ Check: $I_B > 0 A$ $\frac{I_C}{I_B} < \beta \text{ (or } h_{FE})$	
Forward-active	$V_{BE} = 0.7 V$ $I_C = \beta \times I_B$ Check: $I_B > 0 A$ $V_{CE} > 0 V$	
Transistor current gain [β or h_{FE}]	$\beta = \frac{I_C}{I_B}$	

Standard microcontroller chip

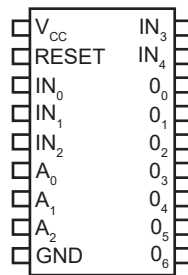

Flow chart symbols

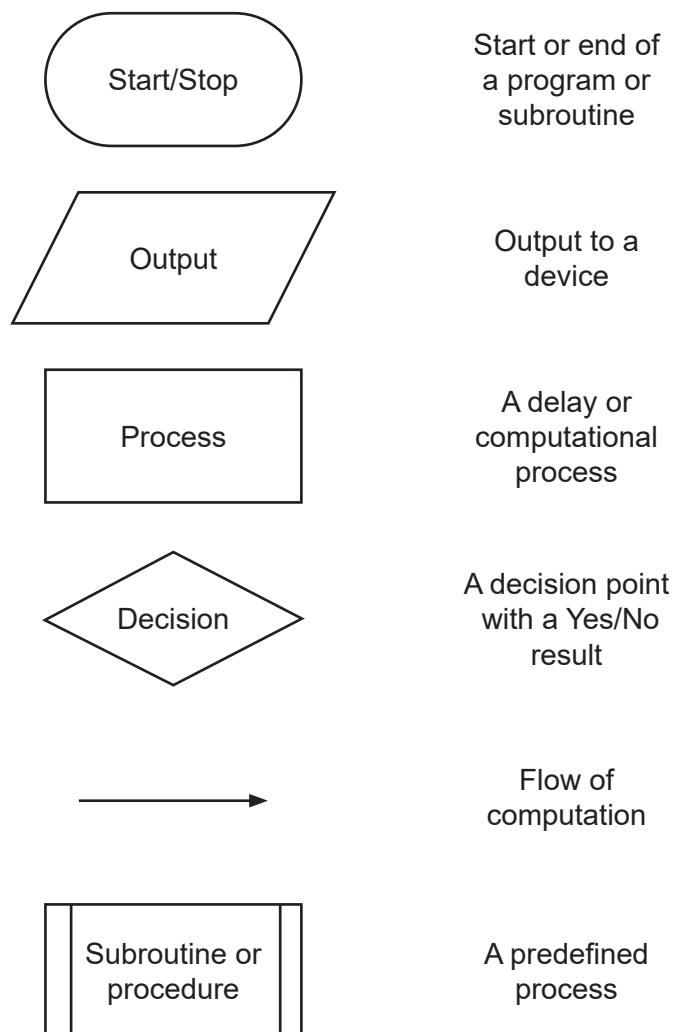

Copyright

© School Curriculum and Standards Authority, 2019

This document – apart from any third-party copyright material contained in it – may be freely copied, or communicated on an intranet, for non-commercial purposes in educational institutions, provided that it is not changed and that the School Curriculum and Standards Authority (the Authority) is acknowledged as the copyright owner, and that the Authority's moral rights are not infringed.

Copying or communication for any other purpose can be done only within the terms of the *Copyright Act 1968* or with prior written permission of the Authority. Copying or communication of any third-party copyright material can be done only within the terms of the *Copyright Act 1968* or with permission of the copyright owners.

Any content in this document that has been derived from the Australian Curriculum may be used under the terms of the Creative Commons [Attribution 4.0 International \(CC BY\)](https://creativecommons.org/licenses/by/4.0/) licence.

An *Acknowledgements variation* document is available on the Authority website.

This document is valid for teaching and examining until 31 December 2024.

*Published by the School Curriculum and Standards Authority of Western Australia
303 Sevenoaks Street
CANNINGTON WA 6107*