



## ATAR course examination, 2022

# PHYSICAL EDUCATION STUDIES

## Practical (performance) examination Netball

### Time allowed

Preparation: 30 minutes  
Examination: 60 minutes (30 minute performance)

### Materials required

*To be provided at the venue*

Non-personal equipment required for Netball

*To be provided by the candidate*

Non-marking athletic shoes

## Structure of the examination

The Physical Education Studies ATAR course examination consists of a written component and a practical (performance) component.

## Criteria for marking the practical (performance) examination

Criteria	Marks available	Percentage of total exam
Skills performance	30	50
Conditioned performance	20	50
<b>Total</b>		100

## Instructions to candidates

1. You are required to wear clothing and personal playing and safety equipment that is approved for competition by the sport's governing body.
2. Clothing must not identify you, your school, club or achievements, and it is requested that you wear black, navy or a white shirt for the examination.
3. You are required to report to a supervisor to register for the practical examination 40 minutes before your scheduled examination time.
4. Once your attendance has been recorded you will be given a coloured, numbered bib to wear for the examination and you will be directed to a supervised warm-up area.
5. Just prior to the scheduled examination time you will be escorted from the warm-up area to the examination area.
6. You must follow the requirements for this examination published in the *Physical Education Studies ATAR course Practical (performance) examination requirements 2022* document.

## SECTION ONE – Skills Performance

## 1. Skills set

(30 marks)

Skill 1	Skill 2	Skill 3	Skill 4	Skill 5
Lob pass	3 feet (0.9m) recovery	Outside foot land and pivot	Split and re-offer	Shadowing

**Drill #1:** Lob pass, 3 feet (0.9m) recovery

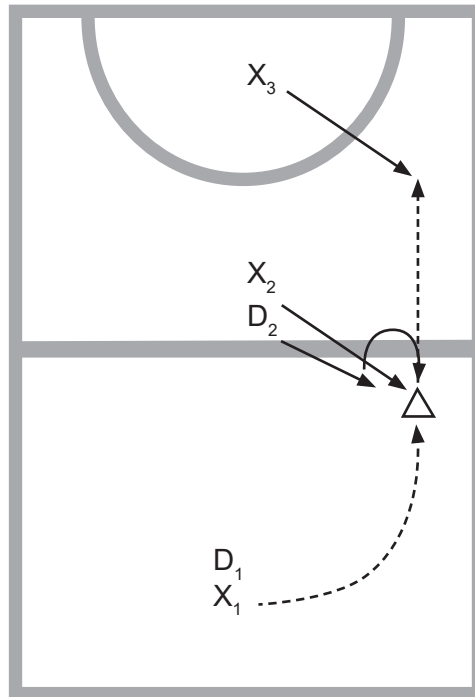

**Key:**

- X = player
- D = defender
- △ = marker
- = player movement
- - - - -> = ball movement

**Drill description:**

1. Player X<sub>1</sub> lobs over defender D<sub>2</sub> to player X<sub>2</sub>.
2. Defender D<sub>2</sub> then does a 3 foot recovery on player X<sub>2</sub> who is passing to player X<sub>3</sub> who leads to receive a pass from player X<sub>2</sub>.
3. Player X<sub>2</sub> passes to leading player X<sub>3</sub>.
3. Repeat on opposite side of court.

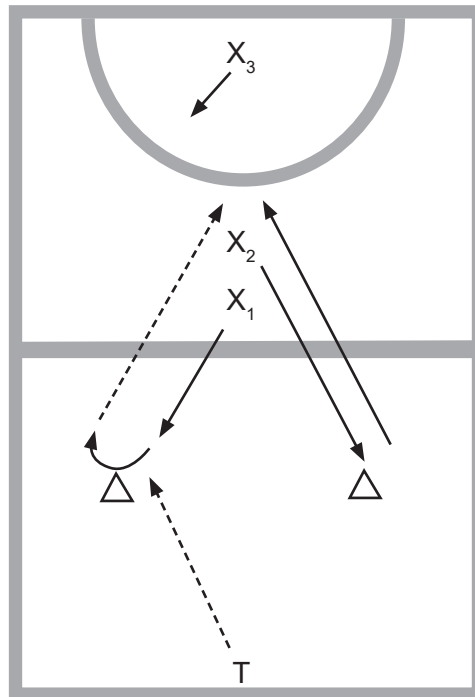
**Drill #2:** Outside foot land and pivot, split and re-offer

**Key:**

- X = player
- T = thrower
- △ = marker
- = player movement
- = ball movement

**Drill description:**

1. Set up in the centre third of the court with thrower (floor supervisor) in the centre circle.
2. Players  $X_1$  and  $X_2$  start behind transverse line.
3. Thrower throws ball to self to create timing for the two attackers to lead.
4. On the catch by the thrower, both players  $X_1$  and  $X_2$  offer a split lead for the ball. Player  $X_1$  has the choice of leading to the left or right but must use a combination of both.
5. Thrower passes to player  $X_1$ .
6. Player  $X_1$  completes the split lead then executes an outside foot land and pivot.
7. Player  $X_2$  completes the split lead then re-offers back down court on an angle.
8. Player  $X_1$  passes a shoulder pass to player  $X_2$  on the re-offer lead.
9. Player  $X_2$  passes to leading player  $X_3$  ( $X_3$  may lead in any direction).

**See next page**

Drill #3: Shadowing

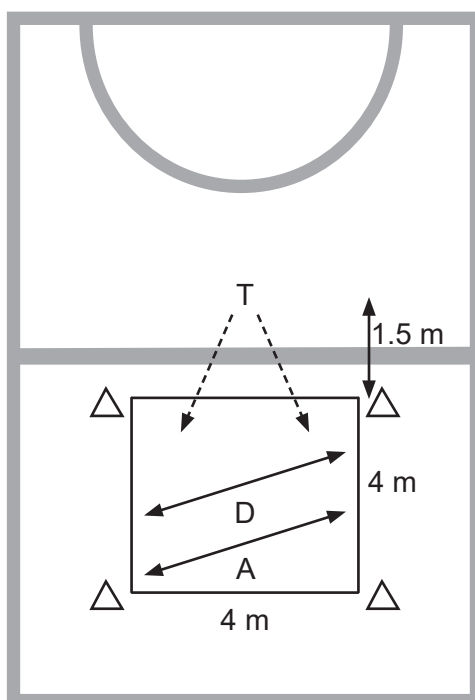

- Key:**
- A = attacker
  - D = defender
  - T = thrower (floor supervision)
  - △ = marker
  - = player movement
  - - - - -> = ball movement

**Drill description:**

1. Skills are to be performed inside the 4 m x 4 m grid set up with markers.
2. The thrower (T) is positioned 1.5 m outside the grid. T throws the ball to self to create timing for the attacker and defender to begin.
3. Starting position for A and D is in the centre of the grid. D takes up a defensive stance with their back to A.
4. On the catch by the thrower, A is to use a dodge in a lateral direction (left and right) using the grid indicated by the markers to evade D and receive a pass. A must receive the pass inside the marked grid.
5. D is to shadow defend A's movements.
6. D must maintain their head position, cover A's movements and intercept or deny the pass.
7. Repeat with head and body positioned the other way.

**See next page**

## SECTION TWO – Conditioned Performance

(20 marks)

SCENARIO PLANNING	
DEFINE PLAYING AREA OR BOUNDARIES	Half court
SPECIFY NUMBER OF PLAYERS	4 vs 4 Offence: GS, GA, WA, C Defence: GK, GD, WD, C
SPECIFY TACTICAL PROBLEM(S) TO BE SOLVED	Creating a scoring shot from a centre pass.
SPECIFY ROLES OR GOALS OF PLAYER(S)	No special notes
SPECIFY OPTIONS, RULES AND/OR RESTRICTIONS	Normal position rules apply. Change offence and defence after 5 minutes.

**Conditioned Performance - Half Court Game Scenario**

1. You will be in Netball Positional Bibs.
2. The rotation of these bibs will be controlled by the Examiners.
3. You will start in traditional playing areas on court.
4. Attackers aim – play from the centre pass to the goal circle and shoot for a goal.
5. Defenders aim – to stop the attackers from getting the ball to a shot for goal.
6. Defenders – if a goal is scored you will take a goal line throw in and play ball past the centre circle.
7. If a defender intercepts the pass, play the ball back past the centre circle and the game recommences with the next centre pass.
8. If the ball is tipped out of court or thrown out of court – the opposition team will be awarded the throw in.
9. All other official Netball rules apply.

**End of examination**

This document – apart from any third party copyright material contained in it – may be freely copied, or communicated on an intranet, for non-commercial purposes in educational institutions, provided that it is not changed and that the School Curriculum and Standards Authority (the Authority) is acknowledged as the copyright owner, and that the Authority's moral rights are not infringed.

Copying or communication for any other purpose can be done only within the terms of the *Copyright Act 1968* or with prior written permission of the Authority. Copying or communication of any third party copyright material can be done only within the terms of the *Copyright Act 1968* or with permission of the copyright owners.

Any content in this document that has been derived from the Australian Curriculum may be used under the terms of the Creative Commons [Attribution 4.0 International \(CC BY\)](https://creativecommons.org/licenses/by/4.0/) licence.

An *Acknowledgements variation* document is available on the Authority website.

<p><i>Published by the School Curriculum and Standards Authority of Western Australia 303 Sevenoaks Street CANNINGTON WA 6107</i></p>
---